



# ROUT & RETURN INSTALLATION

## Rout & Return

*Prefabricated panels can be panned on-site using standard carpentry tools to provide a solid, distinctive finish at a much lower cost.*

<b>Before You Start</b>	<b>1</b>
<b>Installation Instructions</b>	
Preparation	2
Rout & Return	3 – 5
Turning the Corner	6
<b>Essential Equipment and Supplies</b>	<b>7</b>
<b>Panel Maintenance</b>	<b>9</b>

### **Panels with Metallic Paint Finishes:**

The protective masking on the face of each panel should be left in place until work is complete on any given area of an installation. However, to help ensure good color uniformity, periodically remove the masking from half of a panel (peel masking upward from the bottom of the panel) to check for color, scratches, and dents.

On panels with metallic finishes, a good color match is much more difficult to achieve. In this case, two adjoining panels should be periodically checked by removing the masking from half of two panels as the installation progresses. The masking should then be taped back over the panel to protect it.

Should any defects be found, stop work immediately and call Laminators for assistance.

**When installing panels with metallic finishes, it is very important that the directional arrows on the panel masking are oriented in the same direction.**

**Color variation is a characteristic of Aluminum composite panels with metallic paint finishes. Laminators Incorporated DOES NOT warrant a color match for these panels.**

**Substrate and Framing**

Prior to installation, the installer **MUST** verify that the framing and substrate are in compliance with all architects' specifications.

Inspect BOTH primary and secondary wall framing to verify that all girts, angles, channels, studs and sheathing and other structural panel support members and anchorage have been installed within the following tolerances:

1/4" in any 20' length vertically or horizontally

1/2" in any building elevation

Inspect sheathing to verify that sheathing joints are supported by framing and that installation is within flatness tolerances. These surfaces must be even, smooth, sound, clean and dry. If the substrate or framing is not within architectural specifications, the installer must submit a written report to the General Contractor listing conditions that are detrimental to the installation of panels. Do NOT proceed with installation until unsatisfactory conditions have been corrected.

**Summary of Installer Responsibility**

The Panel Installer assumes total responsibility for all components of the panel installation including, but not limited to attachment to sub-construction, panel-to-panel joints, joints between panels and dissimilar material, and the joint seal associated with panel system.

**Installation Supplies & Accessories**

See page 7 to be sure you are using materials that have been tested and approved by Laminators for use with Omega-Lite panels. Inventory all materials and accessories to ensure that all materials are available on-site. Call Tech Support if you need additional recommendations.

**Receiving and Storage**

**Examination:** Upon receipt of materials, perform a thorough examination to identify any damage that may have occurred during shipping. Any damage must be noted on the bill of lading at the time of receipt.

**Storage:** Panels are to be stored horizontally on pallets with a positive slope for drainage of water and should be covered with watertight and ventilated materials. *Standing water will damage panel finish.*

No more than 1500 pounds should be stacked on one pallet. Depending on panel size, this should be fewer than 50 panels at 30 pounds per panel and less than 2-1/2' high. Do not stack other materials on or in contact with panels to prevent staining, denting, or other damage. Storage temperature must not exceed 120°F (49°C).

Laminators' warranty does not cover water damage caused by improper storage or installation. Inspect panels on delivery, then store them on skids 8" above the ground. Place a breathable cover over them and store them in a ventilated space under roof.

If wet panels are discovered, uncrate them and dry them with towels to prevent wood rotting, paint attaining or aluminum corrosion.

**Panel Handling**

Use clean work gloves to avoid hand injury from any sharp edges and to prevent smudging of the prefinished surfaces. Although panels are shipped with protective masking on both sides, always lift one panel completely off the next to prevent scratches. Do not slide one panel across another.

Protect panels from construction hazards. Good construction practice provides for panel protection and cleaning in the contract documents. Normally these are the general contractor's responsibility. Temporary protection may be required if welding, cutting, sandblasting, or other potentially damaging construction activities are scheduled nearby.

**Cutting the Panels**

Omega-Lite panels are designed to be cut to size on the job site. Even if the panels have been received cut to size, it may be necessary to do some minor trimming to account for areas of an elevation that may be out of square. To cut Omega-Lite panels, use a circular saw with a sharp, carbide-tipped blade (40-tooth minimum). Do not remove the protective masking from the panel face. After cutting, use a screwdriver or deburring tool (see page 7) to remove burrs or sharp edges from the panels.

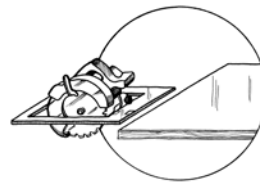

**Carbide-tipped  
blade (40 tooth min.)  
recommended**

**Safety tip: Wear safety glasses when cutting!  
Wear gloves when handling cut edges!**

**Ventilation is Important**

The wood or exterior gypsum board of the substrate must be protected and ventilated. Trapped moisture can cause major damage in a short time. When mounting over exterior gypsum or masonry, use steel strapping or hat channels to separate panels from the structure for good air circulation.

**Flashing**

Laminators can supply flashing materials made from aluminum sheet painted to match the adjacent panel system or surface.

Use proper flashing technique when installing flashing with panels.

Complete CAD details and product specifications can be downloaded from our website **LaminatorsInc.com**

This system is a folded-edge panel mounting system, called "Rout and Return." Using this system, panels can be fabricated on-site, or in a fabricating shop and then installed on the building. The installation gives self-supporting panels made into return edge pans, that traditionally give a 1-1/4" deep reveal that is caulked flush. The system can be installed with small, inexpensive clips located strategically and wet sealed.

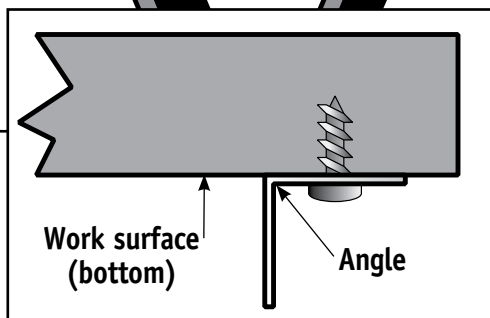
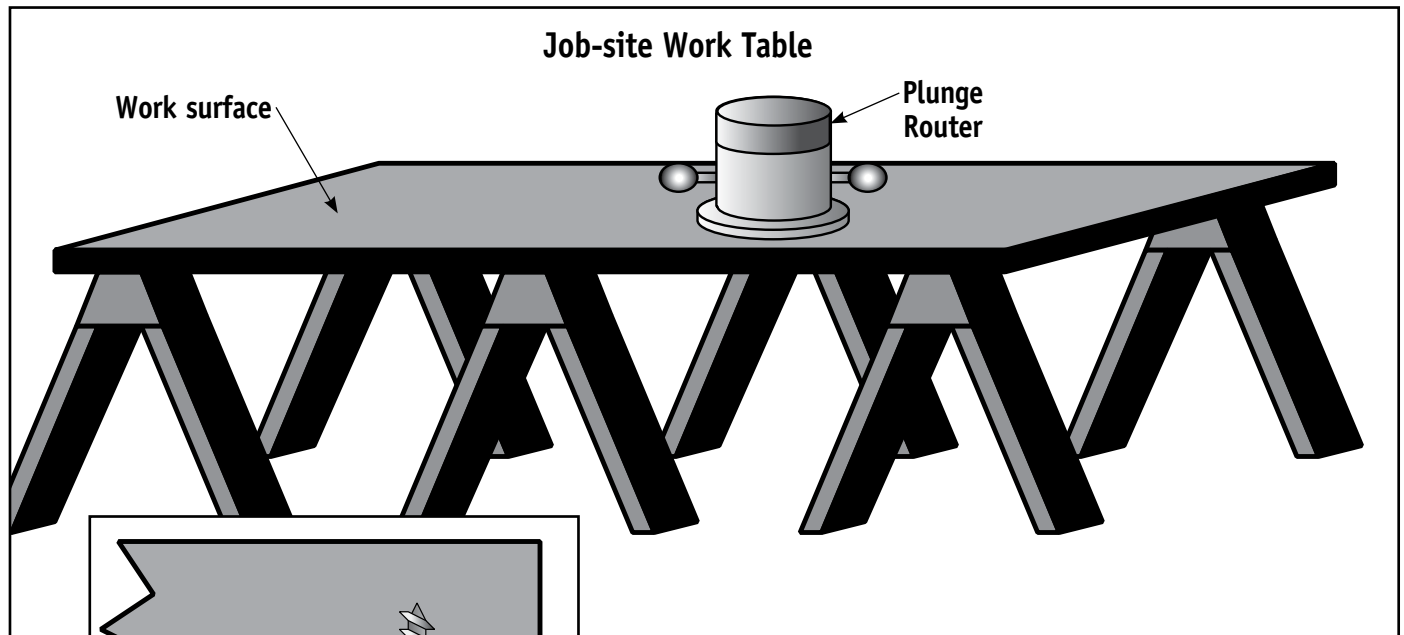

Figure 1

### Step 1: Set up a solid work surface

3/4" particle board and three saw horses work well. For added stability, screw a steel or aluminum angle around the perimeter of the particle board on the underside as shown in **Figure 1**.

You will also need a plunge router that accepts a 1/2" router bit.

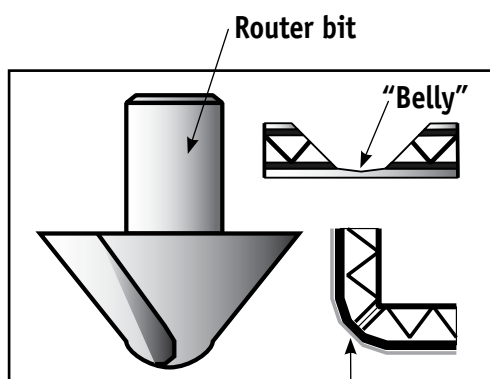

Figure 2

Laminators stocks the correct router bit, (see **Figure 2**) for use with Omega-Lite panels. The tip of the router bit has been tooled so that it is slightly rounded. This creates a slight "belly" at the bottom of the rout. This belly causes the bend location to be slightly rounded, ultimately putting less stress on the aluminum.

*Notice that a correct rout removes some of the back side of the face metal.*

Omega-Lite® panels can be routed and folded for use as a pure Rout & Return system, or routing can be used in conjunction with other Laminators' installation systems for the purpose of turning corners or for fascia-soffit transitions. First we will address the use of Rout & Return as a system.

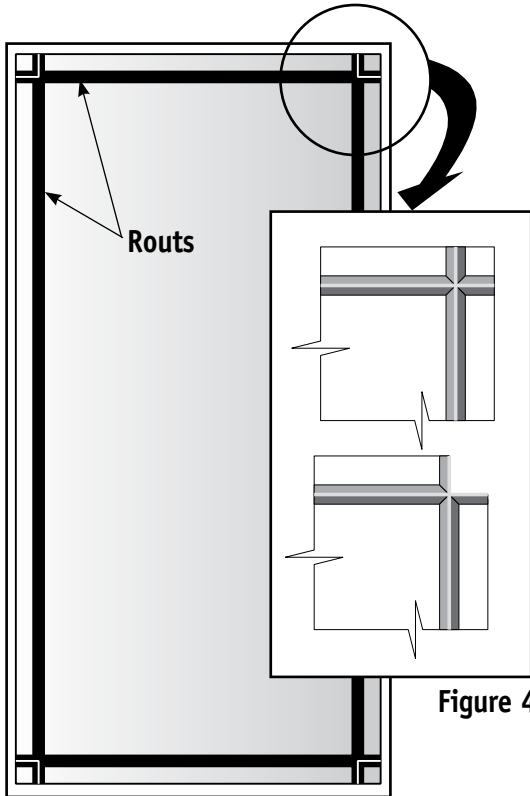

Figure 3

### Step 2: Rout edges of the panel

All four edges of the panel must be routed and folded on the back side of the panel. This allows you to create return legs, which are typically 1". **Figure 3** shows a panel that is face down and has been routed.

**Figure 4** is a close-up of the upper right-hand corner of the panel. The top part of the illustration shows the panel as it appears after routing. On the bottom part of the illustration the corner has been removed so that the panel can be folded. When removing this corner piece, you must cut directly down the middle of the "belly" described on page 2, so that when folded, the corner comes together correctly.

### Step 3: Fold the panel

Prior to folding the panel, the rout should be filled with a Laminators approved silicone caulk, **Figure 5**. This serves two purposes. First, it replaces the material that was removed by the router and provides additional strength. Second, it seals the flutes to keep water out of the panel.

Folding 1" return legs cannot be done by hand. **Figure 6** shows how some installers clamp an aluminum angle to both sides of the return legs to create enough stability to fold them while others simply cut or rout a 1/4" groove about 3/4" deep in a wooden 2x4, place it over the leg, and fold it.

**Figure 7** shows the Omega-Lite panel after the bend locations have been folded.

*See page 7 for Laminators' approved silicone caulk.*

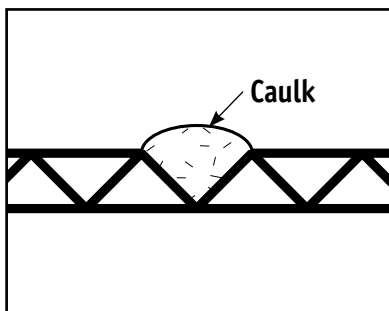

Figure 5

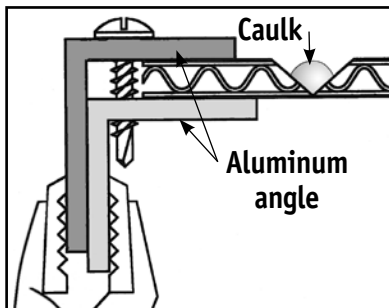

Figure 6

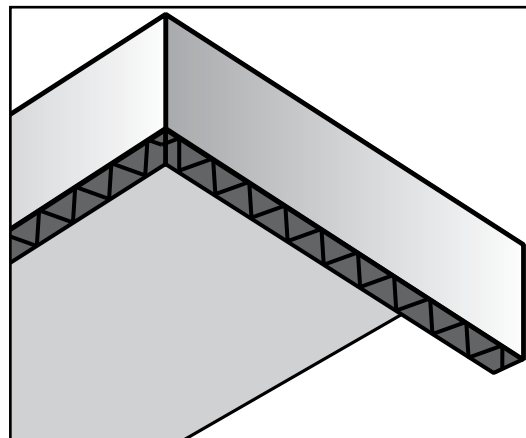

Figure 7

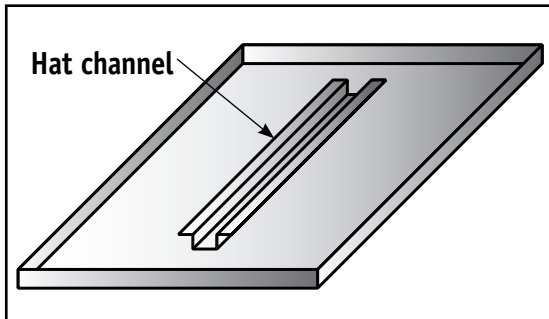

Figure 7

## Step 4: Apply hat channel to the back of the panel

Figure 7 depicts the panel after all four return legs have been folded. A hat channel has been attached using a silicone caulk to the back of the panel to act as a stiffener. This is often done on panels larger than 4' x 4' to add stability or to prevent sagging on soffit panels.

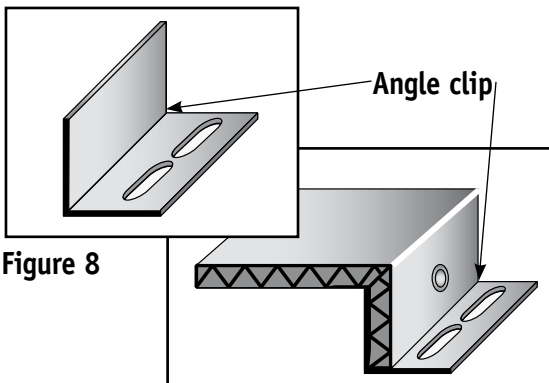

Figure 8

Figure 9

## Step 5: Attach clips to the perimeter of the panel

Many fabricators provide their own attachment systems. Laminators uses 3" long angle clips which are attached every 12" to 16" around the perimeter of the panel. See Figure 8. These can either be screwed, using phillips pan-head S.M.S. #8 x 1/4", or riveted to the panel, as shown in Figure 9. Notice that the clip has two slots in it. The slotted side goes against the wall. The slots allow the installer to adjust the panel before the screws are completely tightened.

Figure 10 illustrates the side of a panel with clips around the perimeter. The panel is now ready to be mounted to the wall surface.

See page 8 for Laminators' attachment clips.

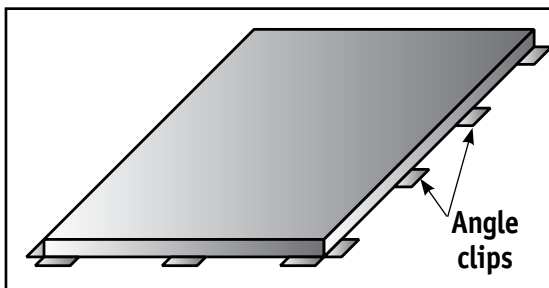
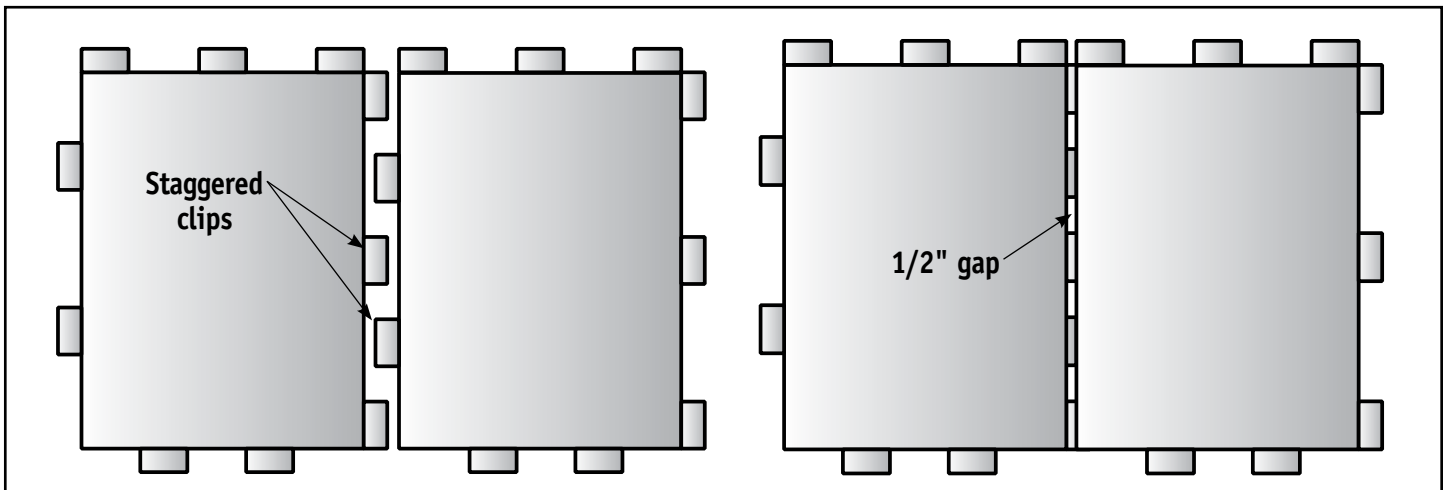

Figure 10

## Step 6: Mount panels to the wall surface

As shown in Figure 11 at the lower left, the clips have been staggered on adjoining panels so that they don't interfere with each other. On the right, panels have been mounted to the wall with a 1/2" gap between them. This is the correct width for the caulk joint that will seal the gap between panels.



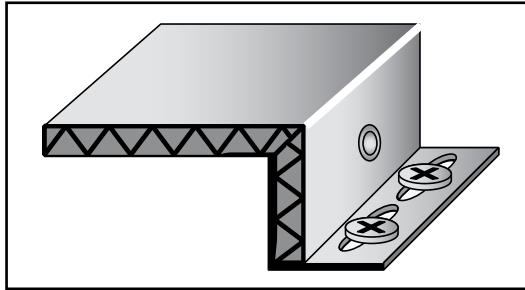

Figure 12

**Figure 12** shows a close-up of a clip fastened to the wall with either pan-head or waffle-head screws.

See page 7 for Laminators' screw accessories.

### Step 7: Tape sides of caulk joint

In preparation for caulking, both sides of the caulk joint are taped off with 2" wide, blue painters' tape.

See **Figure 13**.

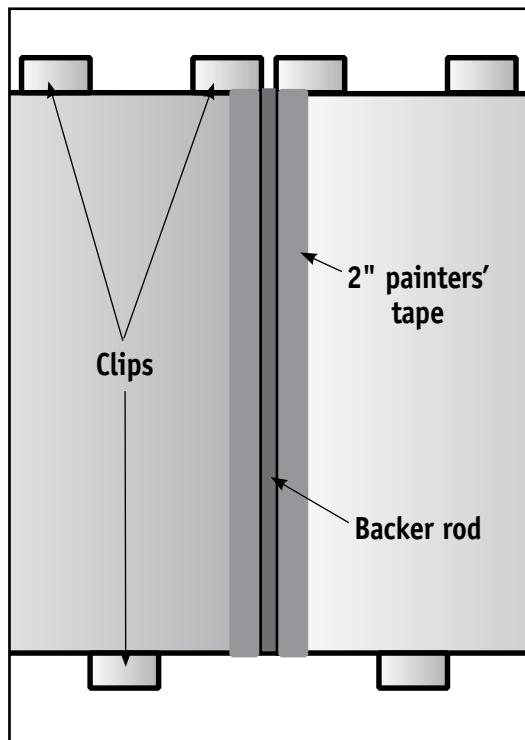

Figure 13

### Step 8: Push backer rod into caulk joint

A good caulk joint should only bond to two opposing surfaces. Three-way adhesion will cause the joint to fail. To prevent three-way adhesion, flexible backer-rod is pushed into the joint. This is a foam material that will not bond to caulk. Backer rod also helps create the thinner area in the center of the caulk joint.

**Figure 13** is an overhead view of the backer rod inserted into the caulk joint.

### Step 9: Caulk the joint

The exposed part of a caulk joint is often tooled with a "caulker's spoon" to create a concave appearance. Some caulkers even tool the joint with the back of an empty caulk tube.

For a caulk joint to function correctly, it should be approximately twice as wide as it is deep, and should be thinner in the middle than at the edges to allow for expansion and contraction without stressing the bond between the caulk and the panel. A correct caulk joint should have an hour-glass shape. See **Figure 14**.

**Figure 14** is a cut-away view of the caulk joint.

When caulking 4-way intersections, caulk all vertical or horizontal joints (your choice) and let the caulk cure before caulking the intersecting joints.

See page 7 for Laminators' approved silicone caulk.

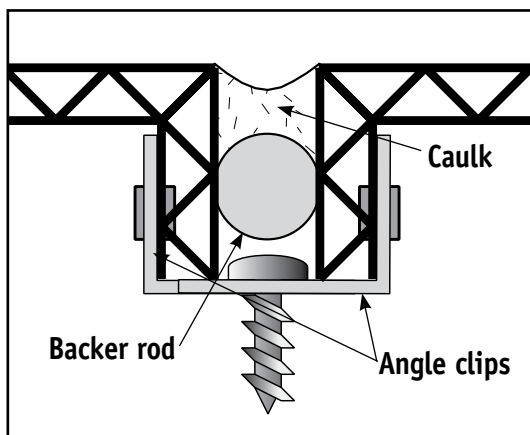

Figure 14

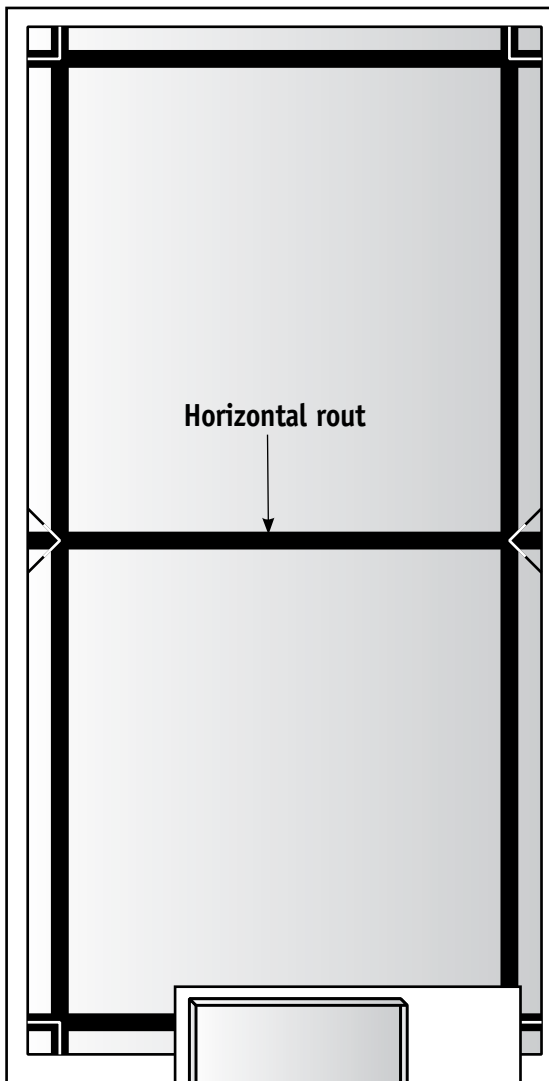

Figure 15

To create a panel that can turn a corner or transition from fascia to soffit, we follow most of the same steps already discussed with the addition of another rout to accommodate our corner. Notice in **Figure 15** the panel has a horizontal rout in the center. On each end of the horizontal routed groove you will notice a triangular area that must be removed before the panel can be folded. Regardless of whether you are bending an inside or outside corner, the panel is always routed on the back side.

**Figure 16** illustrates a folded Omega-Lite panel that is properly prepared for an outside corner.

As with any other routed groove, inside and outside corner locations must be filled with silicone caulk prior to folding the panel. Additionally, 1" x 1" aluminum angles should be caulked to the back side of the corner to strengthen it.

**Figure 17** shows an outside corner panel. **Figure 18** shows an inside corner panel. Again, both panels have been routed on the back and then folded as required.

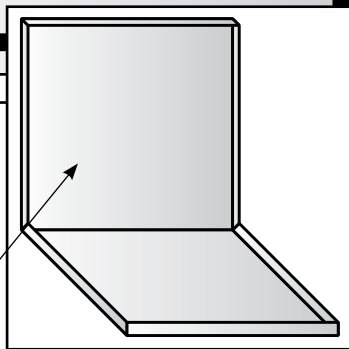

Figure 16

Folded panel for outside corner

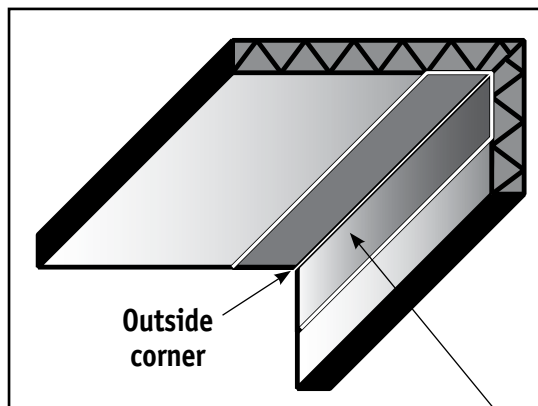

Figure 17

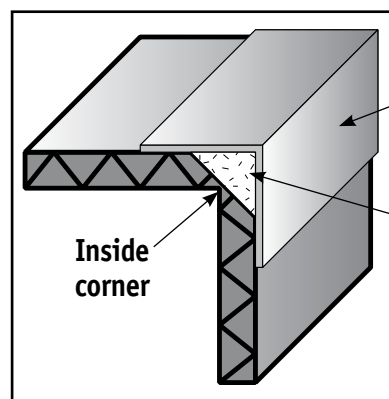

Figure 18

1-inch aluminum angles

Caulk

- Work table or saw horses and 3/4" particle board to create work table
- Aluminum brake capable of bending 0.032" aluminum
- Porter-Cable 3 HP router with guide or equivalent able to accept a 1/2" carbide shank
- Laminators' router bit (Part #RB 1/2)
  - Custom designed router bit only available from Laminators Inc. that forces bending into the middle of the groove and eliminates core show-through. Carbide with 1/2" shank.
- Miter saw or chop saw with 10" diameter blade
- Circular saw with 7-1/4", 40-tooth blade (min.)
- Jigsaw with 24-tooth, sheet metal cutting blade
- Caulking gun
- Screw gun
- Long 1/8" drill bit with drill bit plastic guard tubing
- Deburring tool (Part #DEBURRING TOOL)
- Aviation snips or heavy-duty scissors
- Plastic putty tool or scraper to remove excess caulk and adhesive from panels
- Metal single cut rectangular file with medium teeth
- Utility knife
- Tape measure
- Safety glasses
- Gloves to handle panels

## ESSENTIAL SUPPLIES

- Panels
  - Moldings/extrusions as needed
    - "J" extrusion for drip edge (required) and end of run option (optional)
    - "H" extrusion for end of run option (optional)
    - snap-in extrusions (required)
  - Color-matched flat stock
  - Strapping
    - 0.40" aluminum or 20 ga. galvanized exterior sheet metal strips 3" x 8', 10', or 12'
  - Furring strips or studs as needed
  - Insulation, 3/4" foam to go between furring strips
  - Ice & water shield or flashing
  - Gaska Tape® V710, 3/16" x 2" or equivalent closed cell 7 lb. density polyvinyl chloride foam tape (Laminators Part #12847)
  - Rout & Return clips (Laminators Part #50295)
  - Silicone Caulk—The following caulks have been tested and meet requirements. Color-matched caulk available from Laminators Inc.
    - Tremco Spectrem® 1
    - Dow Corning® 790, 983, 795, 995, 756, 791
    - GE SilGlaze® II, SilPruf®
    - Pecora 860, 896, 895
  - Panel Adhesive—The following adhesives have been tested and meet requirements. Various adhesives available from Laminators Inc.
    - Titebond® Heavy-Duty Construction Adhesive or Premium Polyurethane Construction Adhesive
    - Liquid Nails® 602 Subfloor (LN-602), 950 Polyurethane (LN-950), 902 for Subfloor (LN-902), or 901 for Heavy Construction (LN-901)
    - DAP 4000 Subfloor Adhesive
    - OSI Sealants PL400
  - Screws
    - #6 x 1-1/4" bugle-head drywall or #8 or #10 x 1" Phillips Pan Head for securing clips into sheathing
    - #8 or #10 x 3/4" or longer, TEKS/3 screws to secure clips into steel studs
    - #6 x 1/2" and #6 x 1" Phillips Pan Head, TEKS/2 screws for mounting moldings to plywood or metal
  - Wood shims to assist with spacing between panels
  - Mineral spirits and rags to clean caulk from panels if necessary
  - Touch-up paint
- Note:** Trademarks are registered by the companies noted.

### How Much Will I Need?

For every 100 sq. ft. of Omega-Lite panels you will need:

- 3 tubes 11 oz. silicone caulk
- 1 tube 28 oz. panel adhesive
- 3 rolls 2" x 50' closed cell PVC foam tape



## Omega-Lite Panel Maintenance

### Routine cleaning:

Omega-Lite panels should be washed periodically to keep them bright. Plain water and a clean cloth are all you need to remove ordinary dirt buildup. A mild, non-abrasive household detergent with a clean-water rinse can be used for more stubborn stains. Solvents such as alcohols, mineral spirits, naphtha, turpentine, and xylene can be applied with a soft cloth. Never soak panels in solvents.

### For scratches and rub-marks:

Omega-Lite touch-up paint and re-paint instructions are available from Laminators. For larger paint repairs, call Laminators for standard paints designed for aluminum surfaces available at paint stores.

### Keep harsh solvents away from finish:

Panel finishes are resistant to most but not all solvents and chemicals. You can safely use mineral spirits to remove uncured caulk and paints.

We suggest that the caulk build up enough strength in an overnight cure so that bubbles do not form.

Carefully review the caulk manufacturer's literature for skin formation, tack-free time, and cure times before using. Remember, your environmental condition is the biggest factor in deciding which caulk is appropriate for your project. Caulk only one joint at a time so that the caulk does not skin over before it can be tooled. Only caulk 4' to 6' at a time for a smooth finish.

It is important to only use caulk from our recommended list and to always test your caulk

in the environmental conditions you are currently working in to find the one that works best. Consult with us if your caulk is not performing as expected.

Apply a generous amount of panel adhesive to the sheathing to prevent it from drawing the panel towards the building as it dries; closed cell PVC foam tape should be placed out in the field of the panel where it will shim the adhesive to the proper thickness away from the furring or sheathing.

