



DRY SEAL INSTALLATION MANUAL

CONTENTS

1	Essential Equipment
1	Essential Supplies
2	Panel Preparation
4	Panel Extrusion Preparation
5	Panel Assembly
6	Wall Sheathing Preparation (Over Plywood)
6	Wall Sheathing Preparation (Over Gypsum)
7	Panel Installation
9	Insert Strip Alternate Installation

OVERVIEW

The Dry Seal Installation System from Laminators Inc. features a “deep reveal” look without caulk at the joints. By installing Omega-Lite® panels with the Dry Seal system, you will create a high-performance, pressure-equalized wall system that compartmentalizes the air cavity and allows for drainage and ventilation, reducing moisture-related issues within the wall cavity.

During the installation, Dry Seal panels are fabricated with a 1" return on all four sides with mitered extrusions attached to the back of the panel. Panels are attached to the wall using a combination of end-of-run and divider extrusions. Exposed miter joints are sealed while hidden joints are left open to encourage drainage along the outer plane of the panels.

For a complete set of CAD drawing details, please visit LaminatorsInc.com.

- Worktable and/or sawhorses and 3/4" plywood or MDF to create worktable
- Aluminum brake capable of bending 0.032" aluminum
- PORTER-CABLE 3 HP router with guide or equivalent able to accept a 1/2" carbide shank
- Laminators router bit (Laminators Part #RB 1/2)
 - Custom-designed router bit only available from Laminators Inc. that forces bending into the middle of the groove and eliminates core show-through. Carbide with 1/2" shank.
- Miter saw or chop saw with 10"-diameter blade
- Circular saw with 7-1/4", 40-tooth blade (min.)
- Jigsaw with 24-tooth, sheet metal cutting blade
- Caulking gun
- Screw gun
- Insert bit holder with 1-1/2"-long Phillips bit
- 5" (min.)-long 1/8" drill bit with polypropylene tubing as a guard
- Deburring tool (Laminators Part #DEBURRING TOOL)
- Aviation snips or heavy-duty scissors
- Plastic putty tool or scraper to remove excess caulk and adhesive from panels
- Metal hand file, single-cut plain edge with medium teeth
- Utility knife
- Tape measure
- Safety glasses
- Gloves to handle panels

ESSENTIAL SUPPLIES

- Panels
- Extrusions
 - Panel or Z extrusion (Laminators Part #44DS-Z)
 - Divider or connector extrusion (Laminators Part #44DS-CONNECTOR)
 - End-of-run or starter strip extrusion (Laminators Part #44DS-ENDRUN)
 - H extrusion to assist in bending panel reveals (Laminators Part #4505ALOD)
- Color-matched flat stock for flashings and end-of-run shapes
- Strapping—only required if installing panels over gypsum sheathing
 - 0.40" aluminum or 20 ga. galvanized exterior sheet metal strips 3" x 8', 10', or 12'
- Gaska Tape® V710, 3/16" x 2-1/2" and 5/8" x 1/2" or equivalent closed-cell 7 lb. density polyvinyl chloride foam tape (Laminators Part #44DS-TAPE 2-1/2 and #44DS-TAPE 1/2)
- Blocking plates to protect drainage and ventilation areas (Laminators Part #44DSBLOCKINGPLATE)
- Springs to assist in installation of insert strips at an end-of-run (Laminators Part #44DS-SPRING)
- Caulk (clear)—the following caulks have been tested and meet requirements
 - Pecora 896 Silicone Sealant (Laminators Part #12754)
 - Tremco® Spectrem® 1
 - Dow Corning® 795 Silicone Building Sealant, 791 Silicone Weatherproofing Sealant, or 995 Silicone Structural Sealant
 - GE SilPruf® SCS2000 or SilGlaze® II N10
- Adhesive—the following adhesives have been tested and meet requirements
 - Liquid Nails® Heavy-Duty Construction Adhesive LNP-901 (Laminators Part #12751-29OZ)
 - Titebond® Heavy-Duty Construction Adhesive
 - Surebond SB-400 Structural Adhesive or PS-800 Super Bonding Adhesive
- Screws
 - #6 x 1/4" Phillips Pan Head Type A screw, galvanized, sheet metal, or zinc-coated for assembling panels
 - #8 or #10 x 1" Phillips Pan Head Type 2 self-drilling galvanized, sheet metal, or zinc-coated screws for attaching extrusions to the wall
- Wood shims to assist with spacing between panels
- Mineral spirits and rags to clean caulk from panels if necessary
- Touch-up paint

The above equipment and supplies are available at Grainger, McMaster-Carr, and/or your local building material supplier.

PANEL PREPARATION

1. Measure all as-built wall dimensions prior to fabricating panels.

2. Size panels according to the as-built wall measurements and add 1" to each side of the panel for the return legs.

NOTE: For projects with return legs longer than 1", contact Laminators Inc. for special instructions.

3. Cut panels to size.

NOTE: It is recommended to wear clean gloves when handling panels.

4. Set up a worktable large enough to hold the largest panels flat in both directions. Place panels on the worktable (finished side face down) and remove masking from the backside of the panel.

5. Set up router with the Laminators router bit. We recommend using an oversized and solid edge guide on the router made out of 1/2" high-pressure laminate to ensure a straight v-groove.

6. With router bit centered 15/16" from the edge, carefully rout the first edge of the panel, creating a v-groove. When creating the v-groove, the entire core to the back of the aluminum sheet will be removed during the process. Repeat for each edge.

NOTE: When routing panels, make sure the return legs are between 7/8" to 1" long. For projects with return legs longer than 1", contact Laminators Inc. for special instructions.

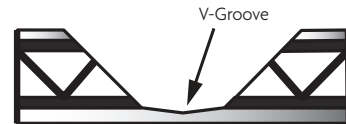

7. Using scissors or snips, notch each of the four corners at the center of the v-groove.

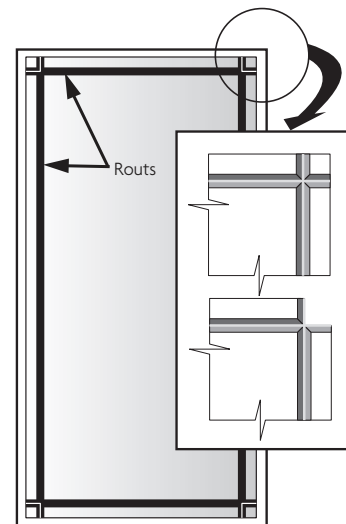

8. Use a deburring tool to smooth all edges of the panels after cutting.

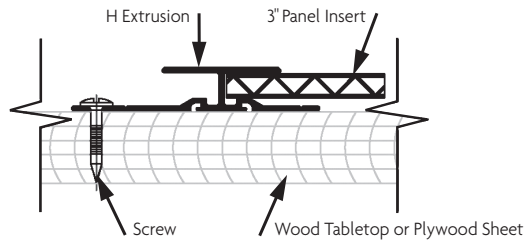

9. To bend panels, cut an H extrusion 2" shorter than the panel dimensions. Screw the extrusion to a 12"-wide x 1/2" (min.)-thick tabletop or sheet of plywood to allow the 1" return to clear the H extrusion. Insert 3"-wide panel strip in the back of the H extrusion to hold the extrusion in place during bending.

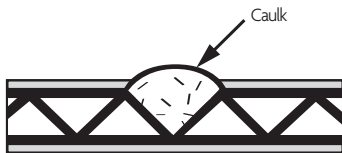

10. Apply caulk to the v-groove to seal the joint prior to bending.

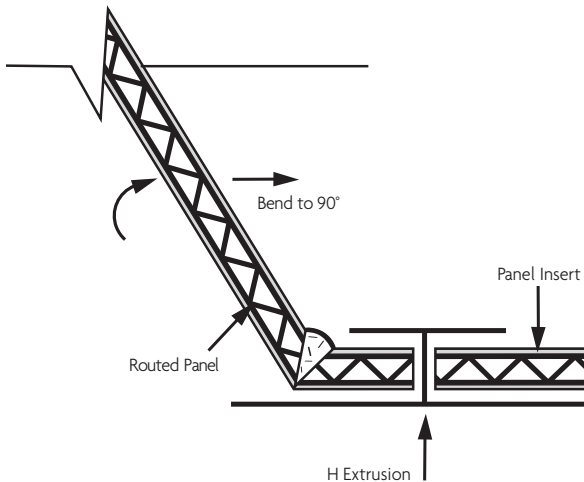

11. Starting with the long edges, bend each edge creating a 90° angle on all four sides. This can be done by inserting the edge into the H extrusion and folding up.

12. Clean out excess caulk after bending the panel edges.

NOTE: Panel extrusions may not sit straight and true if installed over protruding caulk beads, and may lead to installation problems later if not addressed immediately.

13. Prepare the next panel and repeat these steps as necessary. Place panels in a clean, dry area until extrusions are prepared and ready for assembly.

PANEL EXTRUSION PREPARATION

1. Panel extrusions are mitered and installed inside the bent edges of the panel, commonly known as a pan. Measure the pan of the panel.

2. Using measurements from step one, set saw at 45° and make first cut. The insert fin will be exposed to the joint side of the panel. Insert a shim between the extrusion and the saw's guide to keep the cut straight and true.

NOTE: For safety purposes, be sure to cut the box edge of the extrusion first; if the blade hits the insert fin first, it may bend and throw the extrusion.

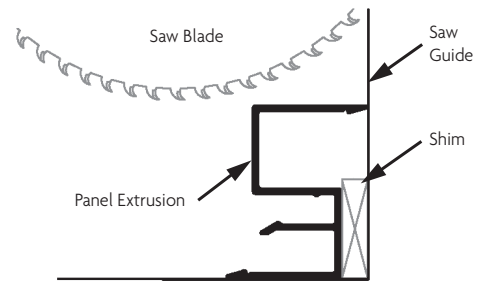
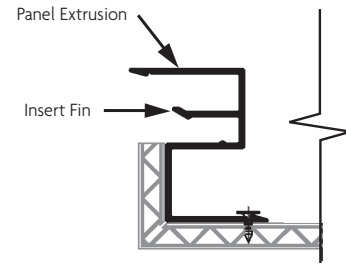

3. Once the first cut has been made, advance panel extrusion to the length needed and rotate 180° along its axis (or rotate saw 90°). This will be the second cut to the extrusion.

4. Continue mitering extrusions and repeat steps as necessary.

NOTE: For measurement, the length of the extrusion tip to tip will be 3/8" longer than the outside dimension of the pan.

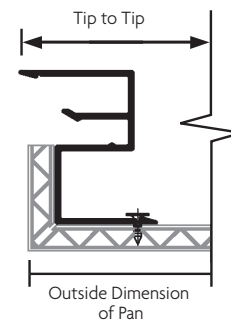

1. Place mitered extrusions into panel to verify proper fit. Remove and apply 1/4"- to 5/16"-diameter bead of caulk into the inside corner of the return leg.

2. Using a scraper, smooth the caulk to form a fillet at the vertical or horizontal joints.

NOTE: Make sure the inside corner is a right angle and has no interference (such as dried caulk) that may prevent the extrusion from sitting square and true inside the panel. If excess beads of caulk cure, they may prevent the extrusions from seating properly.

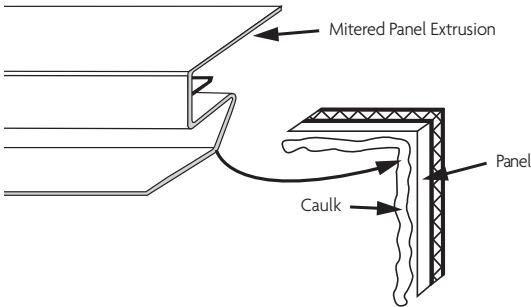

3. Insert appropriate mitered extrusion into wet caulk of the inside corner return leg.

4. Insert remaining extrusions and adjust corners as necessary.

NOTE: The mitered extrusion corners may have gaps up to 1/16". Gaps larger than 1/16" may cause issues during the wall installation.

5. Using the 1/4" screws, attach extrusions to back of panel along the screw line at each end and every 12" on center (O.C.).

6. Apply a bead of caulk on the back of the mitered corner and first vertical joint. Smooth the seals.

7. Use a scraper to remove excess caulk at the inside corner of the return edge. Allow the caulk to cure.

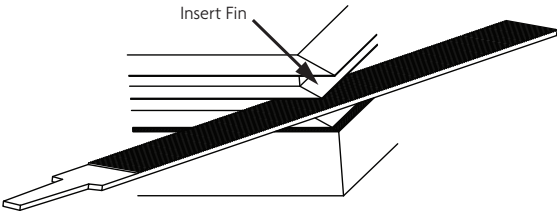

8. After caulk has cured, file the mitered joint using a metal file to remove any burrs and unevenness created by the extrusion joint. A burr-free and smooth joint will allow the insert strips to slide into position without interference.

9. Panels are now ready to install onto the wall.

WALL SHEATHING PREPARATION (OVER PLYWOOD)

1. Sheathing should be prepared with air and water barrier coating to keep water out of the sheathing and wall. If not previously installed, we recommend Sto Gold Coat® 265 or Henry Company Air Bloc® 31. Refer to manufacturers' installation instructions.
2. Create and apply flashings from flat stock as necessary. Caulk the top edges of the sill flashing. Refer to SMACNA Standards.
3. Apply 2-1/2" foam tape on the wall in continuous verticals to compartmentalize the system. Tape must be placed at each vertical panel joint.
4. Apply foam tape at the horizontal joints with 1" breaks on either side of vertical tape (min. 2 breaks for every 8' of panel). These breaks allow for drainage and ventilation in the system.
5. Firmly press tape against sheathing to get a good bond.
6. Peel paper masking off of tape.

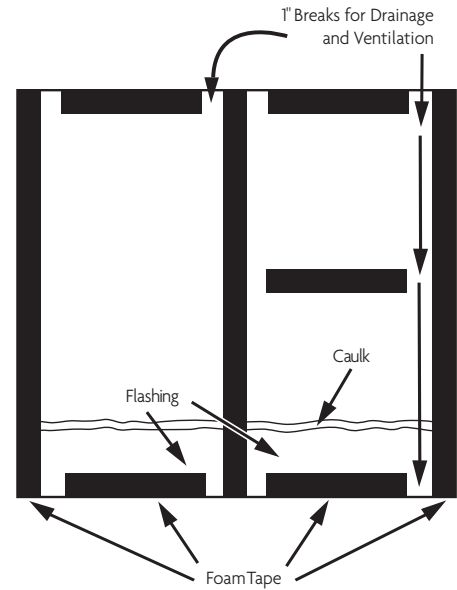

WALL SHEATHING PREPARATION (OVER GYPSUM)

Gypsum sheathing is not strong enough to support the weight and wind loads on fasteners, so strapping attached to the framing behind is needed.

1. Sheathing should be prepared with air and water barrier coating to keep water out of the sheathing and wall. If not previously installed, we recommend Sto Gold Coat® 265 or Henry Company Air Bloc® 31. Refer to manufacturers' installation instructions.
2. Create flashings from flat stock as necessary and attach through gypsum board, into the framing behind. Caulk the top edges of flashing. Refer to SMACNA Standards.
3. At all panel joint locations, apply 3"-wide strapping fastened with screws into framing behind.
4. Apply 2-1/2" foam tape over strapping in continuous verticals to compartmentalize the system. Tape should be centered at each vertical panel joint.
5. Apply foam tape at horizontal joints with 1" breaks on either side of vertical tape. These breaks allow for drainage and ventilation in the system.
6. Firmly press tape against sheathing to get a good bond.
7. Peel paper masking off of tape.

When installing panels, it is best to start at the bottom and at a vertical end-of-run (i.e., outside corner), working up and out.

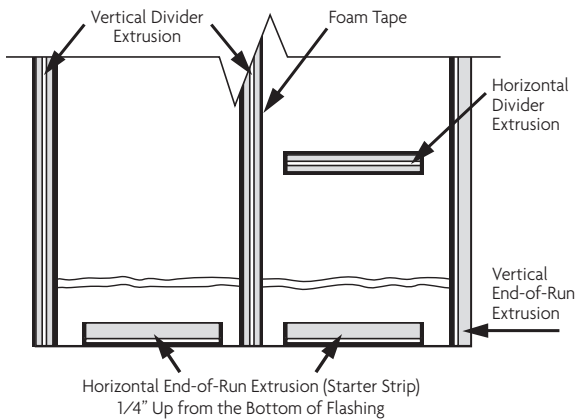

1. Install end-of-run extrusion over flashing to act as a starter strip. Placement of the extrusion should be 1/4" up from bottom of flashing on a typical 3/4" joint installation. If other than 3/4" joint, end-of-run extrusion should be 1/2" below the bottom of the panel.

NOTE: The end-of-run/starter strip should not cover the 1" break for drainage and ventilation in the horizontal run of foam tape.

2. Install end-of-run extrusion at vertical position.

3. Insert panel into starter strip and end-of-run extrusions by placing the bottom and vertical edges between the foam tape and the backside of the extrusions.

NOTE: It may be helpful to use wood shims to assist in maintaining consistent joint widths.

4. Using 1" screws, install the next horizontal and vertical divider extrusion over the foam tape along the side and top of the first installed panel. Fasten the screws 12" O.C. and at all horizontal panel joints.

NOTE: The vertical extrusion piece should be continuous at the joint with no open gaps. The horizontal extrusions should be the same length as horizontal foam tape.

5. Using a long 1/8" drill bit protected by polypropylene tubing, pre-drill a hole for a locking screw by drilling through the edge of the divider extrusion and panel extrusion. Insert a 1" screw into the pre-drilled hole to lock the panel into place.

NOTE: Each panel should have at least one locking screw that goes through the divider and panel extrusions.

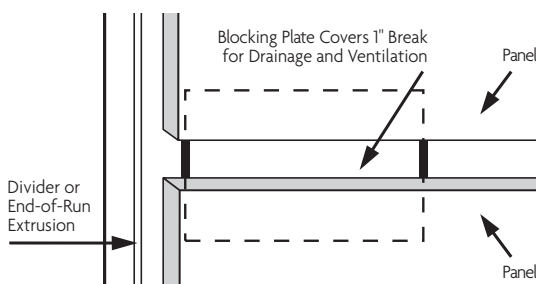

6. Install blocking plates at every horizontal joint over the 1" break for drainage and ventilation. Slide and place edge of blocking plate next to divider or end-of-run extrusion.

7. Measure and size the bottom horizontal insert strip to fit between the starter strip extrusion and flashing. After cutting the insert strip, deburr edges and remove masking.

NOTE: Horizontal insert strips at the bottom and top, as well as at an end-of-run, are smaller width than the typical joints. For 3/4" joints, insert strips 1-5/8"-wide work well. Adjust width of insert strips accordingly for larger or smaller joints.

8. Slide the bottom horizontal insert strip between the starter strip extrusion and flashing.

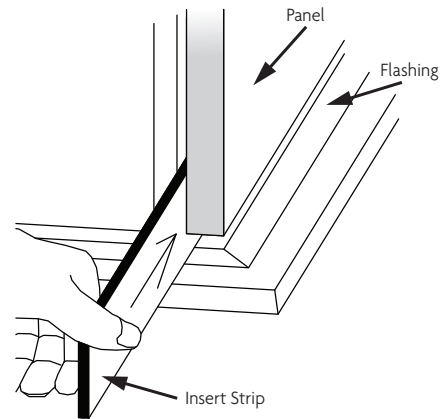

9. Continue installing panels and divider extrusions along the vertical joints, working up and out from the end-of-run, locking the panels in place as you go.

10. Measure and size horizontal and vertical insert strips to fit between the installed panels. After cutting insert strips, deburr edges and remove masking.

NOTE: For 3/4" joints, insert strips 2-3/8"-wide (2-5/8" max.) work well between panels. Adjust width of insert strips accordingly for larger or smaller bottom joints.

11. The vertical insert strips are slid or placed into vertical panel extrusions and the next panel is placed with the corners of the panel extrusion started under the starter strip at the lower corner, and under the vertical divider extrusion at the lower corner.

12. Continue these steps until all panels are installed to the wall.

NOTE: It is recommended to remove masking after all panels are installed. However, due to the size and scope of each project, it may be necessary to remove masking as panels or sections of panels are installed.

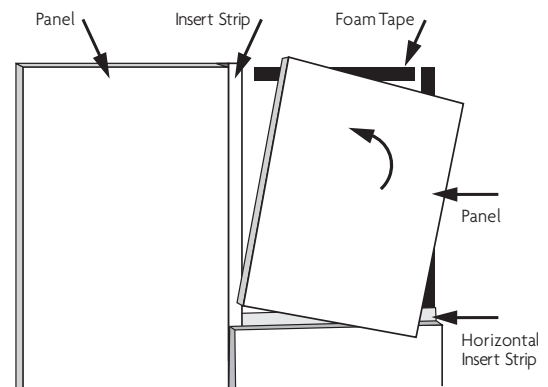

13. Place flashings or end-of-run shapes at locations such as doors, windows, and transitions to other construction materials. Refer to SMACNA Standards.

In the event that insert strips cannot be slid into place from the end, Laminators provides a method to “snap-in” insert strips after panels are installed and secured.

1. Place small piece of foam tape 1/2"-wide x 3"-long into the joint and stick it to the bottom of the joint. Attach foam tape 36" O.C.

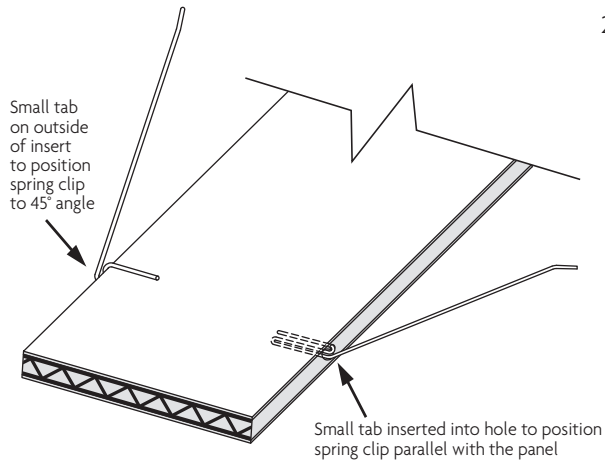

2. This insert strip is prepared by drilling 1/8" holes on both sides of the core every 24" O.C., and then pushing springs into place. The springs on the first inserted side go in at a 45° angle down toward the back of the insert. (The small tab of the spring goes on the outside of the insert making the 45° angle.)

A second spring is inserted on the other side parallel and forward. This allows the strip to be pushed easily into place from the top of the joint.

NOTE: For an end-of-run, springs are only needed on the side against the panel.

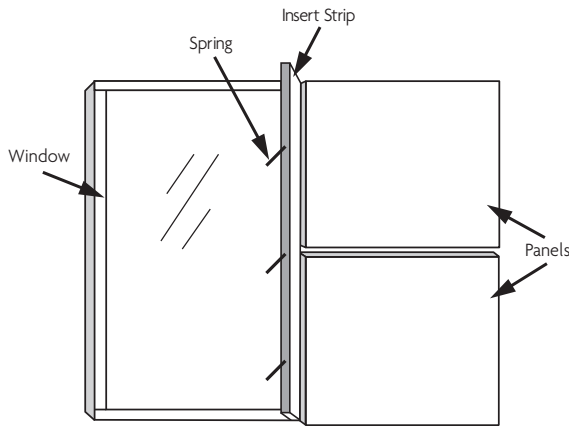

3. Put the 45° angle side in between the panel first.
4. Push the strip into the joint at an angle. The springs will slide into position. The insert strip will drop below the edge of the other panel, and will stay in place while the trailing springs are pushed into the joint.

5. Push the trailing springs down into the joint with your finger until they snap down into the joint between the two panels.

6. The insert strip is now centered and located in position.

