



ICC-ES Listing Report

Reissued February 2024

ESL-1248

This listing is subject to renewal February 2025.

CSI: DIVISION: 07 00 00—THERMAL AND MOISTURE PROTECTION
Section: 07 42 43 – Composite Wall Panels

Product Certification System:

The ICC-ES product-certification system includes evaluating reports of tests of standard manufactured product, prepared by accredited testing laboratories and provided by the listee, to verify compliance with applicable codes and standards. The system also involves factory inspections, and assessment and surveillance of the listee's quality system.

Product: OMEGA-LITE® ACM PANELS

Listee: LAMINATORS INC.

Evaluation: Omega-Lite® ACM panels were evaluated for use in Types I, II, III or IV construction based on a tested exterior non-load-bearing wall assembly consisting of building materials components described in the Assembly Section, tested in accordance with the following standard:

- NFPA 285 (-12 and -06), Standard Fire Test Method for Evaluation of Fire Propagation Characteristics of Exterior Non-Load-Bearing Wall Assemblies Containing Combustible Components, National Fire Protection Association.

Assemblies: Omega-Lite® ACM panels are prefabricated panels consisting of a 0.185-inch (4.7 mm) thick extruded polypropylene core bonded to an unfinished 0.013-inch (0.33 mm) thick aluminum backer sheet on one side and a finished 0.028-inch (0.71 mm) thick aluminum sheet on the other side to create an overall panel thickness of 0.24-inch (6 mm) nominal; the panels and the concealed fastening installation systems (1-Piece, Tight-Fit Molding and Clip & Caulk) are installed on the exterior face of exterior walls of buildings required to be of Type I, II, III, or IV construction with the following conditions. See Figures 1 through 8 for assembly details.

1-Piece, Tight-Fit Molding Installation System Option 1 – Over Exterior Gypsum Sheathing (See Figures 1 and 2)

Interior Finish: The interior surface of the wall assembly must be clad with one layer of 5/8-inch-thick (15.9 mm) National Gypsum Gold Bond® Fire-Shield® gypsum wallboard, complying with ASTM C1396. The gypsum wallboard must be fastened to the wall framing with No. 6 x 1¼-inch long (31.8 mm), bugle head, self-drilling screws with a nominal spacing of 8 inches (203 mm) around the board perimeter and 12 inches (305 mm) in the field. The fasteners and joints must be covered with joint tape and joint compound in accordance with ASTM C840 or GA216.

The wall must be framed with 35/8-inch (92.1 mm) wide 18 GA galvanized steel studs spaced 16 in. on-center (406 mm) fastened to 35/8-inch (92.1 mm) wide 18 GA galvanized steel track. The studs must be connected to the track with one No. 6 x ½-in. long self-drilling, pan head fastener per stud flange. Minimum 8-inch thick (203 mm) mineral wool safing pieces, with a nominal density of 4 lbs/ft³ (64 kg/m³) must be installed per the manufacturer's installation instructions to fit into each stud cavity placed at each floor line. 15 ¼ inch wide by 47 inch long by 3 ½ inch thick (387 mm by 1194 mm by 89 mm) R15 semi-rigid batt stone wool insulation must be friction fitted inside each stud cavity of the assembly.

Exterior Finish: One layer of 5/8-inch-thick (15.9 mm) National Gypsum Gold Bond® eXP® exterior gypsum sheathing, complying with ASTM C1177, must be placed horizontally across the full exterior surface of the assembly; a vertical joint offset of 16 inches (406 mm) was used during installation. The gypsum sheathing

must be fastened to the wall framing with No. 6 x 1¼-in. (31.8 mm) long, bugle head, self-drilling screws with a nominal spacing of 8 inches (203 mm) around the board perimeter and 12 inches (305 mm) in the field. For the air and vapor barrier / water-resistive barrier of this assembly, Carlisle Coatings and Waterproofing Fire Resist Barritech™ VP fluid-applied membrane must be directly applied over gypsum sheathing, where the Barritech™ VP must be roller-applied at a nominal wet mil thickness of 60 mils or nominal dry mil thickness of 40 dry mils.

Sub-Framing for Exterior Cladding: Back-Drained and Ventilated BD&V Sub-framing consist of 6005A-T61 aluminum extrusions 7/8 inch (22.2 mm) deep and thickness varying from 0.078 to 0.100 inch (1.98 mm to 2.54 mm) thick; and must be fastened to the assembly with No. 8 x ¾ inch (19.1 mm) Hex Washer Head screws used on each end of the extrusions marked as “FV” and with No. 10 x 1 ½ inch self-drilling Hex Washer Head screws spaced 16 inches (406 mm) on center with extrusions marked as “SH” or “EJ”. 2 inch (50.8 mm) wide by 3/16 inch (4.76 mm) thick closed-cell PVC foam tape with a nominal density of 7 lb/ft³ (112.1 kg/m³) must be applied to the face of the sub-framing extrusions in strips 16 inches (406 mm) on center in the panel field. ¼ inch to 3/8 inch (6.35 mm to 9.53 mm) bead of panel adhesive must be applied to the face of the sub-framing extrusions in a 2 inch by 3 inch (50.8 mm by 76.2 mm) Z formation nominally spaced 16 inches (406 mm) in the panel field.

Omega-Lite® ACM Panels: 0.24-inch (6 mm) nominal thick Omega-Lite® ACM panels must be secured to the BD&V sub-framing using J-moldings, termination J-moldings, and H-moldings. The moldings were secured to the sub-framing using No. 8 x ½ inch (12.7 mm) long self-drilling Phillips Pan Head Screws. The moldings used No. 8 x ½-inch (12.7 mm) long self-drilling Phillip Pan Head and Phillip Modified Truss Head Screws 12 inches (304.8 mm) on center and in accordance with Manufacturer’s recommended installation instructions. The completed assembly with panels and sub-framing must be cured a minimum of 7 days.

Window Detailing: At window openings, 3 5/8-inch (92.1 mm) 18 GA galvanized steel track sections must be mechanically fastened with No. 6 x ½ inch (12.7 mm) long self-drilling Philip Pan Head screws at each corner, where the Barritech™ VP must not be applied on any of the window opening framing. For flashing at the window openings, a two-part 22 GA steel flashing was added before cladding installation and must be attached along the horizontal leg of the 18 GA galvanized steel track using No. 12 x 1 inch (25.4 mm) long self-drilling hex washer head screws staggered every 6 inches (152.4 mm) on center while the vertical leg of the 18 GA galvanized steel track must be attached using No. 8 x 1 ¼ inch (31.8 mm) long self-drilling Philips Modified Truss Head Screws every 16 inches (406 mm) on center. 0.028 inch (0.71 mm) thick aluminum flashing must be installed over the steel flashing and parts of the window opening, window jamb and sill with No. 8 x ½ inch (12.7 mm) long self-drilling Philips Modified Truss Head screws at 16 inches (406 mm) on center.

1-Piece, Tight-Fit Molding Installation System Option 2 – Over Omega CI Rigid Insulation (See Figures 3 and 4)

Interior Finish: The interior surface of the wall assembly must be cladded with one layer of 5/8-inch-thick (15.9 mm) National Gypsum Gold Bond® Fire-Shield® gypsum wallboard, complying with ASTM C1396. The gypsum wallboard must be fastened to the wall framing with No. 6 x 1¼-inch long (31.8 mm), bugle head, self-drilling screws with a nominal spacing of 8 inches (203 mm) around the board perimeter and 12 inches (305 mm) in the field. The fasteners and joints must be covered with joint tape and joint compound in accordance with ASTM C840 or GA216.

The wall must be framed with 3 5/8-inch (92.1 mm) wide 18 GA galvanized steel studs spaced 16 in. on-center (406 mm) fastened to 3 5/8-inch (92.1 mm) wide 18 GA galvanized steel track. The studs must be connected to the track with one No. 6 x ½-in. long self-drilling, pan head fastener per stud flange. Minimum 8-inch thick (203 mm) mineral wool safing pieces, with a nominal density of 4 lbs/ft³ (64 kg/m³) must be installed per the manufacturer’s installation instructions to fit into each stud cavity placed at each floor line. 15 ¼ inch wide by 47 inch long by 3 ½ inch thick (387 mm by 1194 mm by 89 mm) R15 semi-rigid batt stone wool insulation must be friction fitted inside each stud cavity of the assembly.

Exterior Finish: One layer of 5/8-inch-thick (15.9 mm) National Gypsum Gold Bond® eXP® exterior gypsum sheathing, complying with ASTM C1177, must be placed horizontally across the full exterior surface of the assembly; a vertical joint offset of 16 inches (406 mm) was used during installation. The gypsum sheathing must be fastened to the wall framing with No. 6 x 1¼-in. (31.8 mm) long, bugle head, self-drilling screws with a nominal spacing of 8 inches (203 mm) around the board perimeter and 12 inches (305 mm) in the field. The gypsum sheathing must be covered with 2.1 inch thick (53.3 mm) Omega CI rigid insulation panels, where the panels were cut to offset and staggered 16 inches (406 mm) from the gypsum sheathing joints. Omega CI panels consist of closed-cell 1½ inch (38.1 mm) thick polyisocyanurate foam core bonded to 5/8 inch (15.9 mm) thick fire treated plywood, where the nominal thickness of each panel is 2.1 inches (53.3 mm) and must be fastened to the exterior wall 16 inches (406 mm) on-center at every steel stud location with ¼ x 4 inch (6.35 mm x 101.6 mm) long self-drilling fasteners at a nominal spacing of 8 inches (203 mm) along the vertical panel edges and 16 inches (406 mm) on center in the panel field and horizontal panel edges. The panels were cut so that every row has a vertical joint offset of 16 inches (406.4 mm). For the air and vapor barrier / water-resistive barrier of this assembly, Carlisle Coatings and Waterproofing Fire Resist Barritech™ VP fluid-applied membrane must be directly applied over the Omega CI panels, where the Barritech™ VP must be roller-applied at a nominal wet mil thickness of 60 mils or nominal dry mil thickness of 40 dry mils.

Sub-Framing for Exterior Cladding: Back-Drained and Ventilated Sub-framing, marked as “SH”, “AH”, and

"EJ, consist of 6005A-T61 aluminum extrusions 7/8 inch (22.2 mm) deep and thickness varying from 0.078 to 0.100 inch (1.98 mm to 2.54 mm) thick; and must be fastened to the assembly with No. 10 x 1 ½ inch self-drilling Hex Washer Head screws spaced 16 inches (406 mm) on center. 2 inch (50.8 mm) wide by 3/16 inch (4.76 mm) thick closed-cell PVC foam tape with a nominal density of 7 lb/ft³ (112.1 kg/m³) must be applied to the face of the sub-framing extrusions in strips 16 inches (406 mm) on center in the panel field. ¼ inch to 3/8 inch (6.35 mm to 9.53 mm) bead of panel adhesive must be applied to the face of the sub-framing extrusions in a 2 inch by 3 inch (50.8 mm by 76.2 mm) Z formation nominally spaced 16 inches (406 mm) in the panel field.

Omega-Lite® ACM Panels: 0.24-inch (6 mm) nominal thick Omega-Lite® ACM panels must be secured to the BD&V sub-framing using J-moldings, termination J-moldings, and H-moldings. The moldings were secured to the sub-framing using No. 8 x ½ inch (12.7 mm) long self-drilling Phillips Pan Head Screws. The moldings used No. 8 x ½-inch (12.7 mm) long self-drilling Phillip Pan Head and Phillip Modified Truss Head Screws 12 inches (304.8 mm) on center and in accordance with Manufacturer's recommended installation instructions. The completed assembly with panels and sub-framing must be cured a minimum of 7 days.

Window Detailing: At window openings, 3 5/8-inch (92.1 mm) wide 18 GA galvanized steel track sections must be mechanically fastened with No. 6 x ½ inch (12.7 mm) long self-drilling pan head screws at each corner, where the Barritech™ VP must not be applied on any of the window opening framing. For flashing at the window openings, a two-part 22 GA steel flashing was added before cladding installation and must be attached along the horizontal leg of the 18 GA galvanized steel track using No. 12 x 1 inch (25.4 mm) long self-drilling hex washer head screws staggered every 6 inches (152.4 mm) on center while the vertical leg of the 18 GA galvanized steel track must be attached using No. 8 x 1 ¼ inch (31.8 mm) long self-drilling Phillips Modified Truss Head Screws every 16 inches (406 mm) on center. At the window jamb locations, 22 GA steel flashing must be fastened using fasteners used to install the sub-framing 0.028 inch (0.71 mm) thick aluminum flashing must be installed over the steel flashing and parts of the window opening, window jamb and sill with No. 8 x ½ inch (12.7 mm) long self-drilling Phillips Modified Truss Head screws at 16 inches (406 mm) on center.

Clip & Caulk Installation System Option 1 – Over Exterior Gypsum Sheathing (See Figures 5 and 6)

Interior Finish: The interior surface of the wall assembly must be cladded with one layer of 5/8-inch-thick (15.9 mm) National Gypsum Gold Bond® Fire-Shield® gypsum wallboard, complying with ASTM C1396. The gypsum wallboard must be fastened to the wall framing with No. 6 x 1¼-inch long (31.8 mm), bugle head, self-drilling screws with a nominal spacing of 8 inches (203 mm) around the board perimeter and 12 inches (305 mm) in the field. The fasteners and joints must be covered with joint tape and joint compound in accordance with ASTM C840 or GA216.

The wall must be framed with 3 5/8-inch (92.1 mm) wide 18 GA galvanized steel studs spaced 16 in. on-center (406 mm) fastened to 3 5/8-inch (92.1 mm) wide 18 GA galvanized steel track. The studs must be connected to the track with one No. 6 x ½-in. long self-drilling, pan head fastener per stud flange. Minimum 8-inch thick (203 mm) mineral wool safing pieces, with a nominal density of 4 lbs/ft³ (64 kg/m³) must be installed per the manufacturer's installation instructions to fit into each stud cavity placed at each floor line. 15 ¼ inch wide by 47 inch long by 3 ½ inch thick (387 mm by 1194 mm by 89 mm) R15 semi-rigid batt stone wool insulation must be friction fitted inside each stud cavity of the assembly.

Exterior Finish: One layer of 5/8-inch-thick (15.9 mm) National Gypsum Gold Bond® eXP® exterior gypsum sheathing, complying with ASTM C1177, must be placed horizontally across the full exterior surface of the assembly; a vertical joint offset of 16 inches (406 mm) was used during installation. The gypsum sheathing must be fastened to the wall framing with No. 6 x 1¼-in. (31.8 mm) long, bugle head, self-drilling screws with a nominal spacing of 8 inches (203 mm) around the board perimeter and 12 inches (305 mm) in the field. For the air and vapor barrier / water-resistive barrier of this assembly, Carlisle Coatings and Waterproofing Fire Resist Barritech™ VP fluid-applied membrane must be directly applied over the gypsum sheathing, where the Barritech™ VP must be roller-applied at a nominal wet mil thickness of 60 mils or nominal dry mil thickness of 40 dry mils.

Sub-Framing for Exterior Cladding: Back-Drained and Ventilated BD&V Sub-framing consist of 6005A-T61 aluminum extrusions 7/8 inch (22.2 mm) deep and thickness varying from 0.078 to 0.100 inch (1.98 mm to 2.54 mm) thick; and must be fastened to the assembly with No. 8 x ¼ inch (19.1 mm) Hex Washer Head screws used on each end of the extrusions marked as "FV" and with No. 10 x 1 ½ inch self-drilling Hex Washer Head screws spaced 16 inches (406 mm) on center with extrusions marked as "SH" or "EJ". 2 inch (50.8 mm) wide by 3/16 inch (4.76 mm) thick closed-cell PVC foam tape with a nominal density of 7 lb/ft³ (112.1 kg/m³) must be applied to the face of the sub-framing extrusions continuously along all the panel joints and in strips 16 inches (406 mm) on center in the panel field. ¼ inch to 3/8 inch (6.35 mm to 9.53 mm) bead of panel adhesive must be applied to the face of the sub-framing extrusions; the beads were continuously applied along all panel joints and 2 inch by 3 inch (50.8 mm by 76.2 mm) Z formation nominally spaced 16 inches (406 mm) in the panel field.

Omega-Lite® ACM Panels: 0.24-inch (6 mm) nominal thick Omega-Lite® ACM panels must be secured to the BD&V sub-framing using steel panel clips 12 inches (304.8 mm) on center with No. 8 x ½ inch self-drilling

Philips Pan Head screws. The horizontal joints located directly over the window opening must include fabricated panel corners with 1 inch (25.4 mm) long return legs, where each leg must be fastened to the exterior gypsum sheathing with a 0.063 inch (1.6 mm) thick aluminum joint clip spaced 12 inches (304.8 mm) on center using No. 6 x ¼ inch self-drilling Philips Pan Head screws; and No. 8 x 1 inch (25.4 mm) long Philips Pan Head screws between each return leg and joint clip. No. 8 x ½ -inch (12.7 mm) long Philips Pan Head screws were used between each joint clip and sub-framing. Closed-cell foam backer rod must be installed along the joint recess; and J-molding and termination J-moldings must be installed with No. 8 x ½ inch (12.7 mm) long self-drilling Philip Pan Head screws and Philip Modified Truss Screws 12 inches (304.8 mm) on center and in accordance with Manufacturer's recommended installation instructions. Moldings must have ½ inch (12.7 mm) wide by ¼ inch thick silicone caulk at all panel joints, where the cure time must be the minimum 7 days.

Window Detailing: At window openings, 3⁵/₈-inch (92.1 mm) wide 18 GA galvanized steel track sections must be mechanically fastened with No. 6 x ½ inch (12.7 mm) long self-drilling pan head screws at each corner, where the Barritech™ VP must not be applied on any of the window opening framing. For flashing at the window openings, a two-part 22 GA steel flashing was added before cladding installation and must be attached along the horizontal leg of the 18 GA galvanized steel track using No. 12 x 1 inch (25.4 mm) long self-drilling hex washer head screws staggered every 6 inches (152.4 mm) on center while the vertical leg of the 18 GA galvanized steel track must be attached using No. 8 x 1 ¼ inch (31.8 mm) long self-drilling Philips Modified Truss Head Screws every 16 inches (406 mm) on center. 0.028 inch (0.71 mm) thick aluminum flashing must be installed over the steel flashing and parts of the window opening, window jamb and sill with No. 8 x ½ inch (12.7 mm) long self-drilling Philips Modified Truss Head screws at 16 inches (406 mm) on center.

Clip & Caulk Installation System Option 2 – Over Omega CI Rigid Insulation (See Figures 7 and 8)

Interior Finish: The interior surface of the wall assembly must be cladded with one layer of 5/8-inch-thick (15.9 mm) National Gypsum Gold Bond® Fire-Shield® gypsum wallboard, complying with ASTM C1396. The gypsum wallboard must be fastened to the wall framing with No. 6 x 1¼-inch long (31.8 mm), bugle head, self-drilling screws with a nominal spacing of 8 inches (203 mm) around the board perimeter and 12 inches (305 mm) in the field. The fasteners and joints must be covered with joint tape and joint compound in accordance with ASTM C840 or GA216.

The wall must be framed with 3⁵/₈-inch (92.1 mm) wide 18 GA galvanized steel studs spaced 16 in. on-center (406 mm) fastened to 3⁵/₈-inch (92.1 mm) wide 18 GA galvanized steel track. The studs must be connected to the track with one No. 6 x ½-in. long self-drilling, pan head fastener per stud flange. Minimum 8-inch thick (203 mm) mineral wool safing pieces, with a nominal density of 4 lbs/ft³ (64 kg/m³) must be installed per the manufacturer's installation instructions to fit into each stud cavity placed at each floor line. 15 ¼ inch wide by 47 inch long by 3 ½ inch thick (387 mm by 1194 mm by 89 mm) R15 semi-rigid batt stone wool insulation must be friction fitted inside each stud cavity of the assembly.

Exterior Finish: One layer of 5/8-inch-thick (15.9 mm) National Gypsum Gold Bond® eXP® exterior gypsum sheathing, complying with ASTM C1177, must be placed horizontally across the full exterior surface of the assembly; a vertical joint offset of 16 inches (406 mm) was used during installation. The gypsum sheathing must be fastened to the wall framing with No. 6 x 1¼-in. (31.8 mm) long, bugle head, self-drilling screws with a nominal spacing of 8 inches (203 mm) around the board perimeter and 12 inches (305 mm) in the field. The gypsum sheathing must be covered with 2.1 inch thick (53.3 mm) Omega CI rigid insulation panels, where the panels were cut to offset and staggered 16 inches (406 mm) from the gypsum sheathing joints. Omega CI panels consist of closed-cell 1½ inch (38.1 mm) thick polyisocyanurate foam core bonded to 5/8 inch (15.9 mm) thick fire treated plywood, where the nominal thickness of each panel is 2.1 inches (53.3 mm) and must be fastened to the exterior wall 16 inches (406 mm) on-center at every steel stud location with ¼ x 4 inch (6.35 mm x 101.6 mm) long DP3 Concealor® self-drilling fasteners at a nominal spacing of 8 inches (203 mm) along the vertical panel edges and 16 inches (406 mm) on center in the panel field and horizontal panel edges. The panels were cut so that every row has a vertical joint offset of 16 inches (406.4 mm). For the air and vapor barrier / water-resistive barrier of this assembly, Carlisle Coatings and Waterproofing Fire Resist Barritech™ VP fluid-applied membrane must be directly applied over the Omega CI panels, where the Barritech™ VP must be roller-applied at a nominal wet mil thickness of 60 mils or nominal dry mil thickness of 40 dry mils.

Sub-Framing for Exterior Cladding: Back-Drained and Ventilated BD&V Sub-framing, marked as "SH", "AH", and "EJ", consist of 6005A-T61 aluminum extrusions 7/8 inch (22.2 mm) deep and thickness varying from 0.078 to 0.100 inch (1.98 mm to 2.54 mm) thick; and must be fastened to the assembly with No. 10 x 1 ½ inch self-drilling Hex Washer Head screws spaced 16 inches (406 mm) on center. 2 inch (50.8 mm) wide by 3/16 inch (4.76 mm) thick closed-cell PVC foam tape with a nominal density of 7 lb/ft³ (112.1 kg/m³) must be applied to the face of the sub-framing extrusions continuously along all the panel joints and in strips 16 inches (406 mm) on center in the panel field. ¼ inch to 3/8 inch (6.35 mm to 9.53 mm) bead of panel adhesive must be applied to the face of the sub-framing extrusions continuously along all panel joints and 2 inch by 3 inch (50.8 mm by 76.2 mm) Z formation nominally spaced 16 inches (406 mm) in the panel field.

Omega-Lite® ACM Panels: 0.24-inch (6 mm) nominal thick Omega-Lite® ACM panels must be secured to the sub-framing using steel panel clips 12 inches (304.8 mm) on center with No. 8 x ½ inch self-drilling Philips Pan Head screws. The horizontal joints located directly over the window opening must include fabricated

panel corners with 1 inch (25.4 mm) long return legs, where each leg must be fastened to the Omega CI panels with a 0.063 inch (1.6 mm) thick aluminum joint clip spaced 12 inches (304.8 mm) on center using No. 6 x ¼ inch self-drilling Philips Pan Head screws and No. 8 x 1 inch (25.4 mm) long Philips Pan Head screws, between each return leg and joint clip. No. 8 x 1 inch (25.4 mm) long self-drilling Philips Pan Head screws are used between each joint clip and Omega CI panel. Closed-cell foam backer rod must be installed along the joint recess; and J-molding and termination J-moldings must be installed with No. 8 x ½ inch (12.7 mm) long self-drilling Philip Pan Head screws and Philip Modified Truss Screws 12 inches (304.8 mm) on center and in accordance with Manufacturer's recommended installation instructions. Moldings must have ½ inch (12.8 mm) wide by ¼ inch thick silicone caulk at all panel joints, where the cure time must be the minimum 7 days.

Window Detailing: At window openings, 3 5/8-inch (92.1 mm) 18 GA galvanized steel track sections must be mechanically fastened with No. 6 x ½ inch long self-drilling pan head screws at each corner, where the Barritech™ VP must not be applied on any of the window opening framing. For flashing at the window openings, a two-part 22 GA steel flashing was added before cladding installation and must be attached along the horizontal leg of the 18 GA galvanized steel track using No. 12 x 1 inch (25.4 mm) long self-drilling hex washer head screws staggered every 6 inches (152.4 mm) on center while the vertical leg of the 18 GA galvanized steel track must be attached using No. 8 x 1 ¼ inch (31.8 mm) long self-drilling Philips Modified Truss Head Screws every 16 inches (406 mm) on center. At the window jamb locations, 22 GA steel flashing must be fastened using fasteners used to install the sub-framing. 0.028 inch (0.71 mm) thick aluminum flashing must be installed over the steel flashing and parts of the window opening, window jamb and sill with No. 8 x ½ inch (12.7 mm) long self-drilling Philips Modified Truss Head screws at 16 inches (406 mm) on center.

Findings: The assemblies described in the Assembly Section, with the Omega-Lite® ACM panels as a component of each wall assembly, complies with the conditions of acceptance described in NFPA 285 when tested in accordance with NFPA 285 for use in Types I, II, III or IV construction, as referenced in the applicable sections of the following code editions.

2018, 2015, and 2012 *International Building Code*®
Applicable Sections: 1402.5 (2015 and 2012 IBC Section 1403.5)

Identification:

1. Packaging of the Omega-Lite® ACM panels carry a label indicating the manufacturer's name (Laminators Inc.) and address, the product name (Omega-Lite® ACM panels), ICC-ES listing number (ESL-1248), and when applicable, the ICC-ES listing mark.
2. The report holder's contact information is the following:

LAMINATORS INC.
3255 PENN STREET
HATFIELD, PENNSYLVANIA 19440
(877) 663-4277
www.laminatorsinc.com

Installation: The product must be installed in accordance with Laminators Inc's published installation instructions and applicable codes.

Conditions of Listing:

1. The listing report addresses only conformance with the standard and code sections noted above.
2. Approval of the product's use is the sole responsibility of the local code official.
3. The listing report applies only to the materials tested and as submitted for review by ICC-ES.
4. The Assembly section describes the assembly using Omega®-Lite ACM panels have been qualified for use in Types I, II, III or IV construction of exterior nonload-bearing wall assembly.
5. The Omega-Lite® ACM panels are manufactured under a quality control program with inspections by ICC-ES.

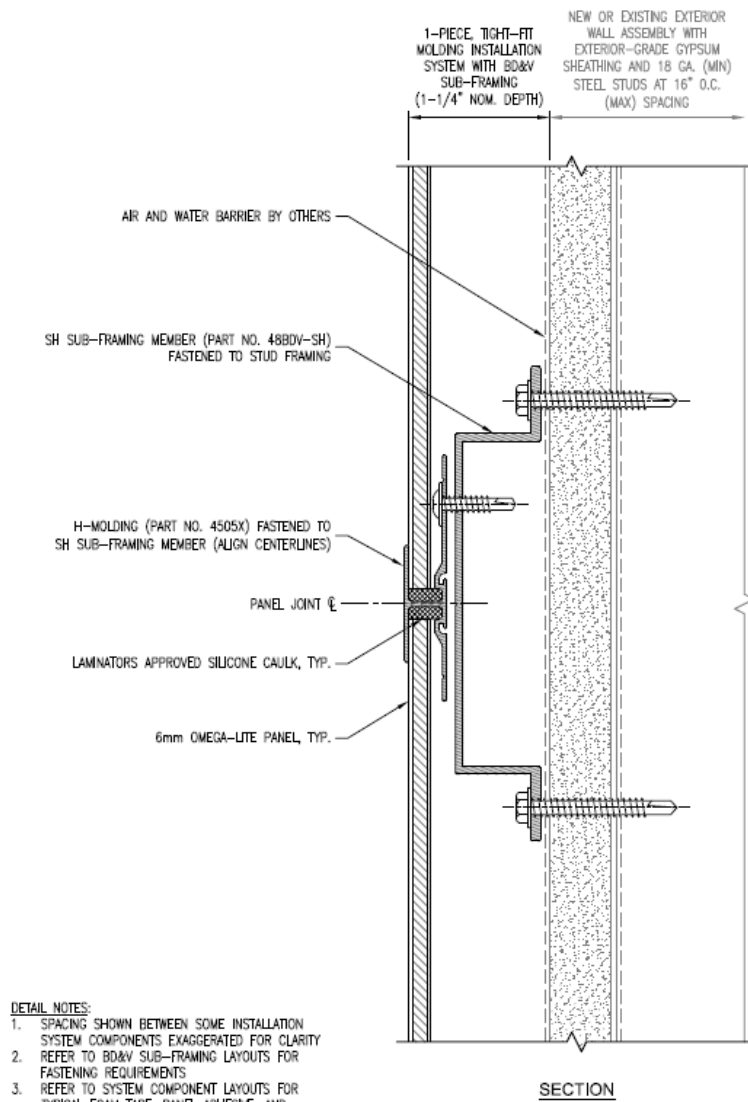

- DETAIL NOTES:**
1. SPACING SHOWN BETWEEN SOME INSTALLATION SYSTEM COMPONENTS EXAGGERATED FOR CLARITY
 2. REFER TO BD&V SUB-FRAMING LAYOUTS FOR FASTENING REQUIREMENTS
 3. REFER TO SYSTEM COMPONENT LAYOUTS FOR TYPICAL FOAM TAPE, PANEL ADHESIVE, AND MOLDING FASTENING REQUIREMENTS

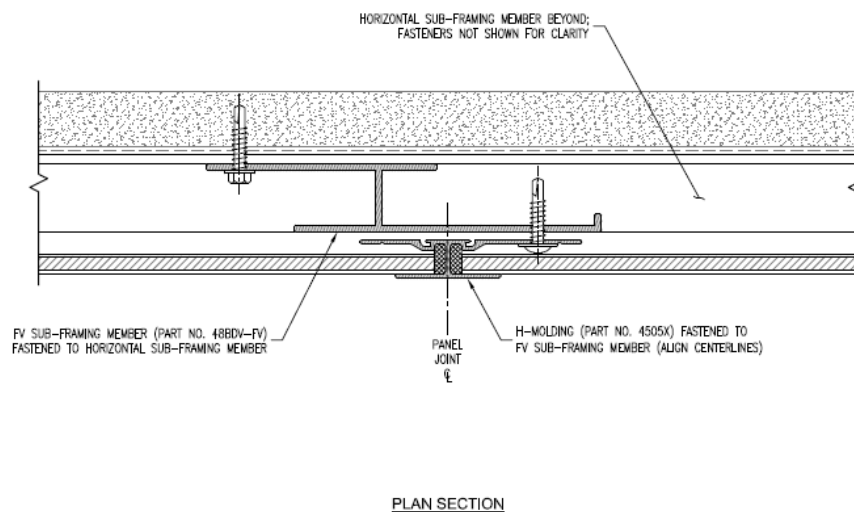

- DETAIL NOTES:**
1. SPACING SHOWN BETWEEN SOME INSTALLATION SYSTEM COMPONENTS EXAGGERATED FOR CLARITY
 2. REFER TO BD&V SUB-FRAMING LAYOUTS FOR FASTENING REQUIREMENTS
 3. REFER TO SYSTEM COMPONENT LAYOUTS FOR TYPICAL FOAM TAPE, PANEL ADHESIVE, AND MOLDING FASTENING REQUIREMENTS
 4. REFER TO S-1.1 OR S-1.2 FOR TYPICAL COMPONENTS NOT ANNOTATED

FIGURE 1: 1-PIECE, TIGHT-FIT MOLDING INSTALLATION SYSTEM WITH SUB-FRAMING OVER GYPSUM SHEATHING JOINT DETAIL (VERTICAL AND HORIZONTAL)

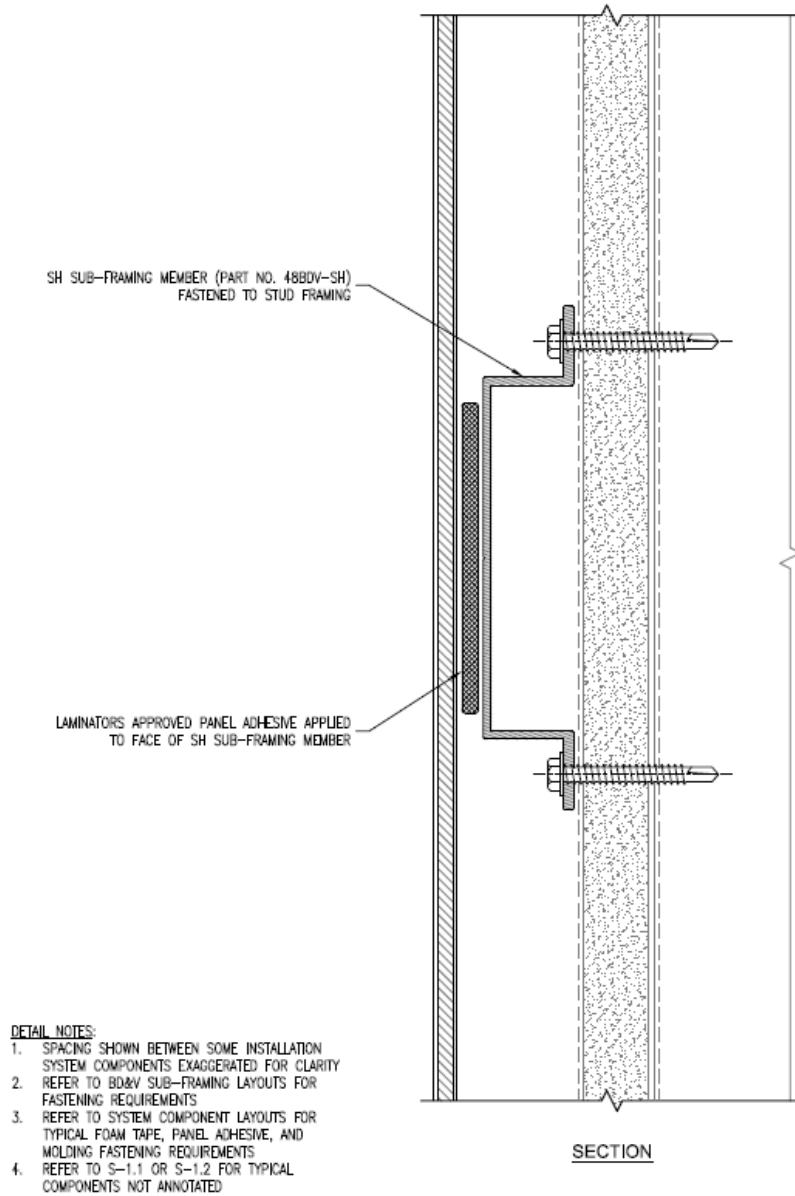

FIGURE 2: 1-PIECE, TIGHT-FIT MOLDING INSTALLATION SYSTEM WITH SUB-FRAMING OVER GYPSUM SHEATHING JOINT DETAIL – (INTERMEDIATE)

NOTE: THIS DETAIL IS APPLICABLE ALONG BOTH HORIZONTAL AND VERTICAL PANEL JOINTS

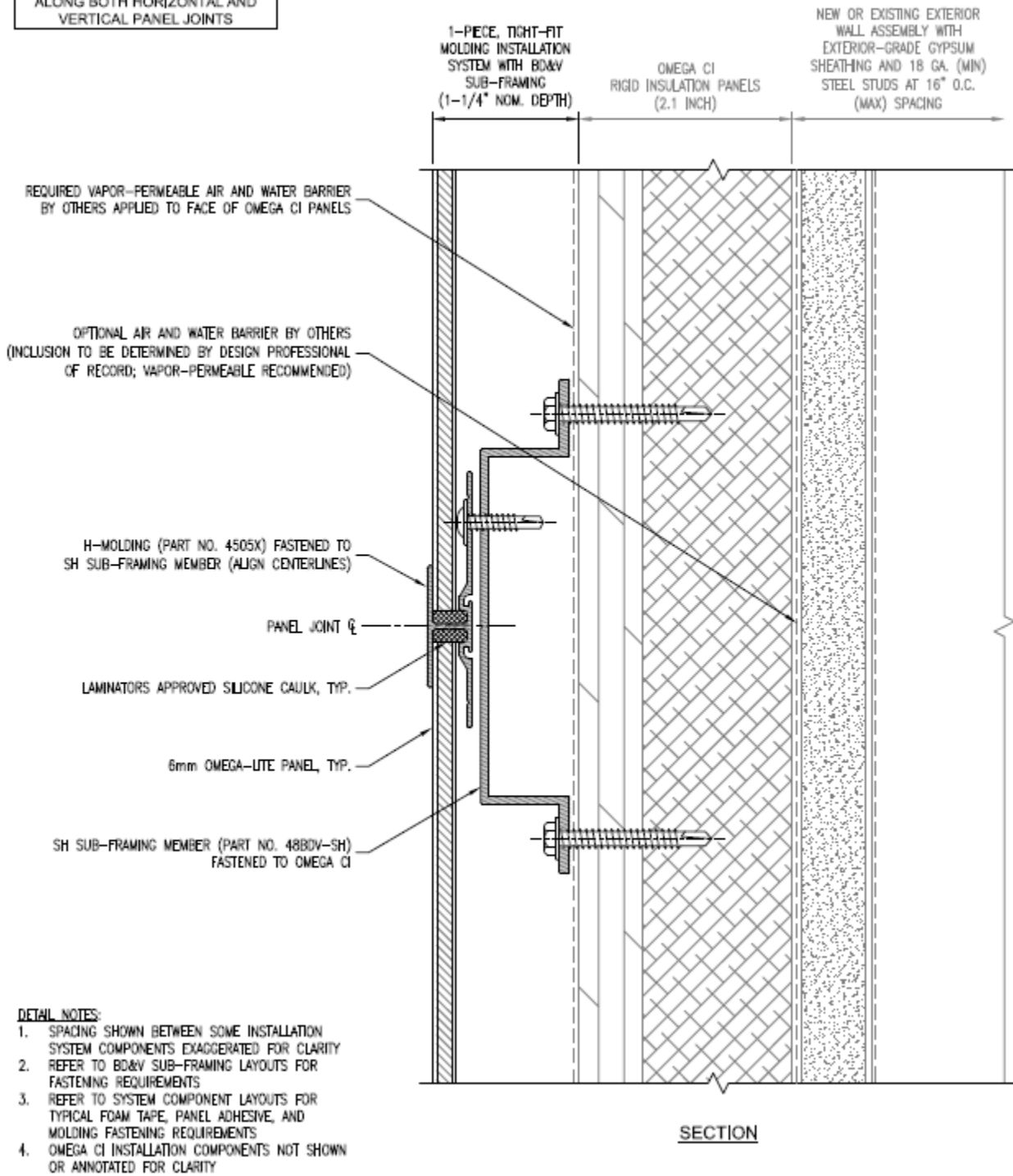
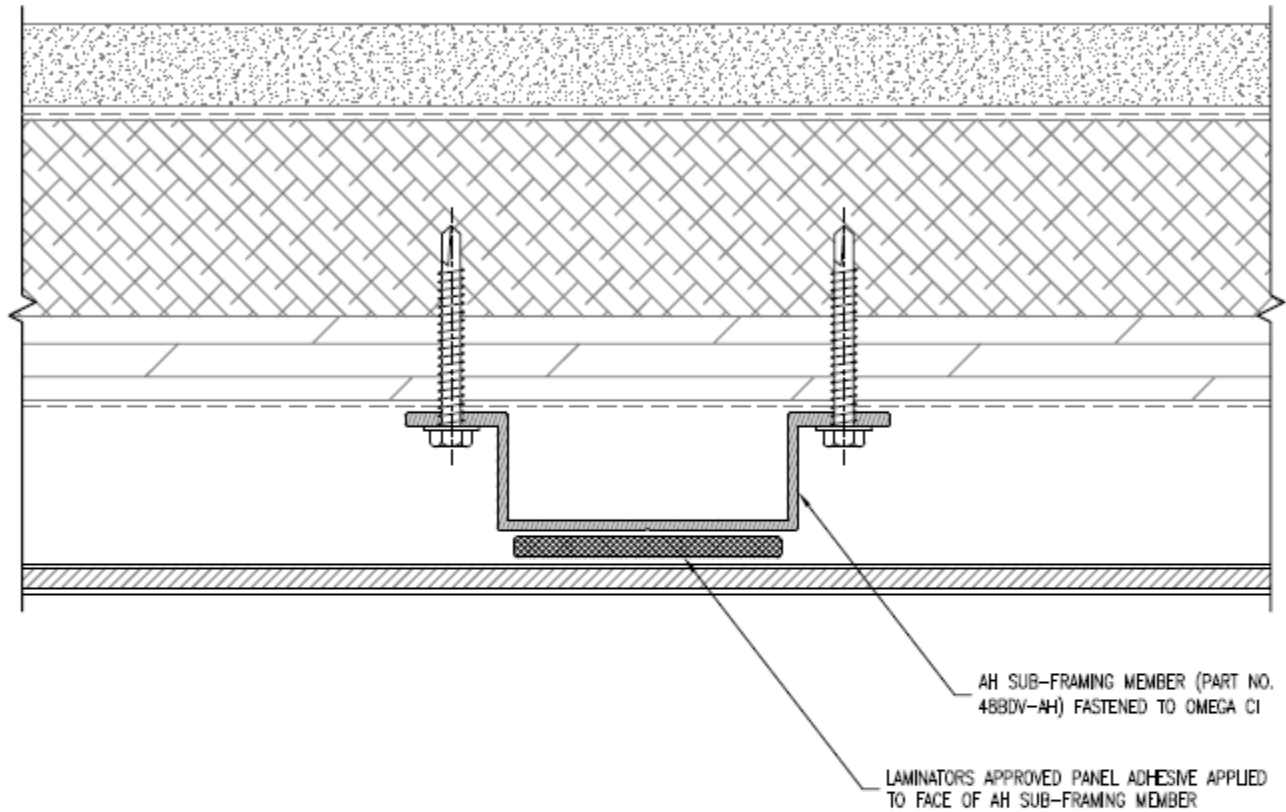

FIGURE 3: 1-PIECE, TIGHT-FIT MOLDING INSTALLATION SYSTEM WITH SUB-FRAMING OVER OMEGA CI RIGID INSULATION JOINT DETAIL (VERTICAL AND HORIZONTAL)



DETAIL NOTES:

1. SPACING SHOWN BETWEEN SOME INSTALLATION SYSTEM COMPONENTS EXAGGERATED FOR CLARITY
2. REFER TO BD&V SUB-FRAMING LAYOUTS FOR FASTENING REQUIREMENTS
3. REFER TO SYSTEM COMPONENT LAYOUTS FOR TYPICAL FOAM TAPE, PANEL ADHESIVE, AND MOLDING FASTENING REQUIREMENTS
4. OMEGA CI INSTALLATION COMPONENTS NOT SHOWN OR ANNOTATED FOR CLARITY
5. REFER TO S-1.1 OR S-1.2 FOR TYPICAL COMPONENTS NOT ANNOTATED

PLAN SECTION

FIGURE 4: 1-PIECE, TIGHT-FIT MOLDING INSTALLATION SYSTEM WITH SUB-FRAMING OVER OMEGA CI RIGID INSULATION JOINT DETAIL – (INTERMEDIATE)

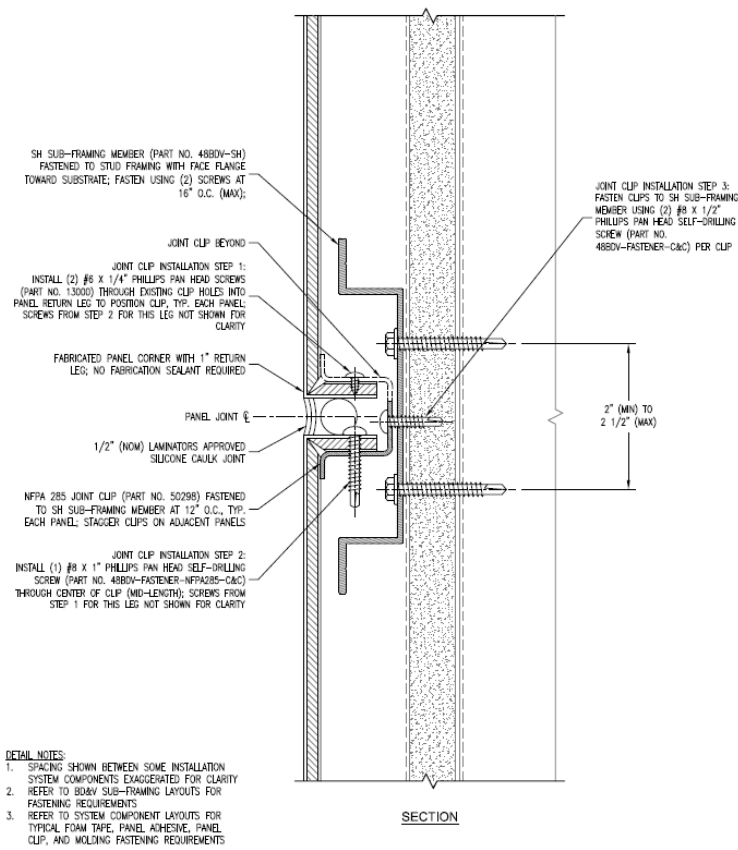

HORIZONTAL JOINT DETAIL (NFPA 285 ZONE)

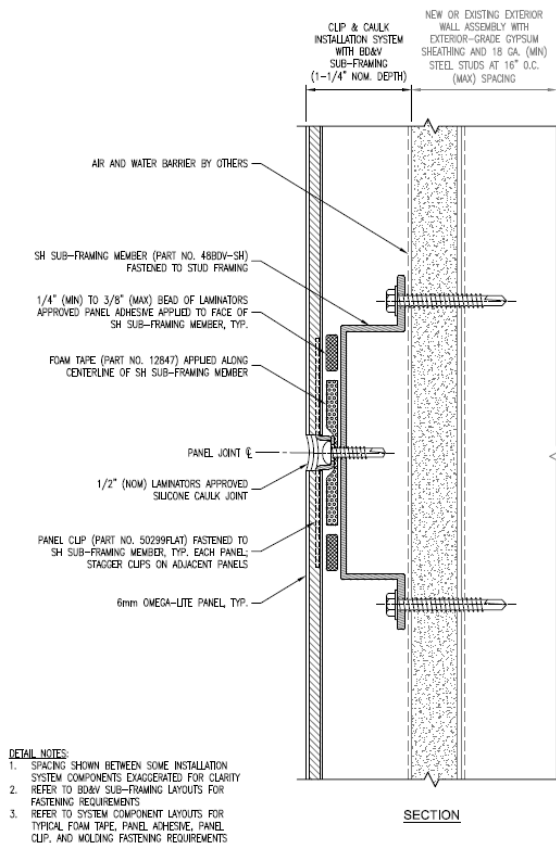

HORIZONTAL JOINT DETAIL

FIGURE 5: CLIP & CAULK INSTALLATION SYSTEM WITH SUB-FRAMING OVER GYPSUM SHEATHING JOINT DETAIL (VERTICAL AND HORIZONTAL)

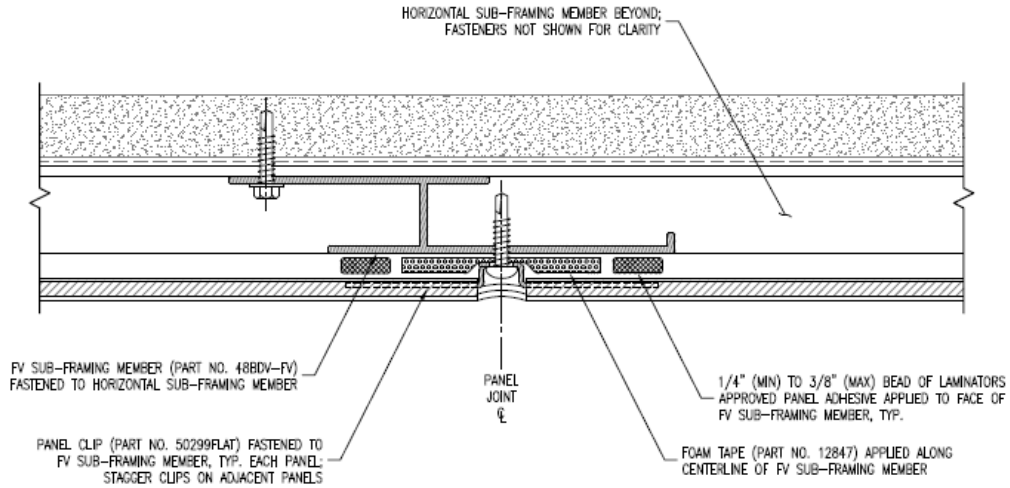

PLAN SECTION

- DETAIL NOTES:**
1. SPACING SHOWN BETWEEN SOME INSTALLATION SYSTEM COMPONENTS EXAGGERATED FOR CLARITY
 2. REFER TO BD&V SUB-FRAMING LAYOUTS FOR FASTENING REQUIREMENTS
 3. REFER TO SYSTEM COMPONENT LAYOUTS FOR TYPICAL FOAM TAPE, PANEL ADHESIVE, PANEL CLIP, AND MOLDING FASTENING REQUIREMENTS
 4. REFER TO S-1.1 FOR TYPICAL COMPONENTS NOT ANNOTATED

VERTICAL JOINT DETAIL

FIGURE 5: CLIP & CAULK INSTALLATION SYSTEM WITH SUB-FRAMING OVER GYPSUM SHEATHING JOINT DETAIL (VERTICAL AND HORIZONTAL) - CONTINUED

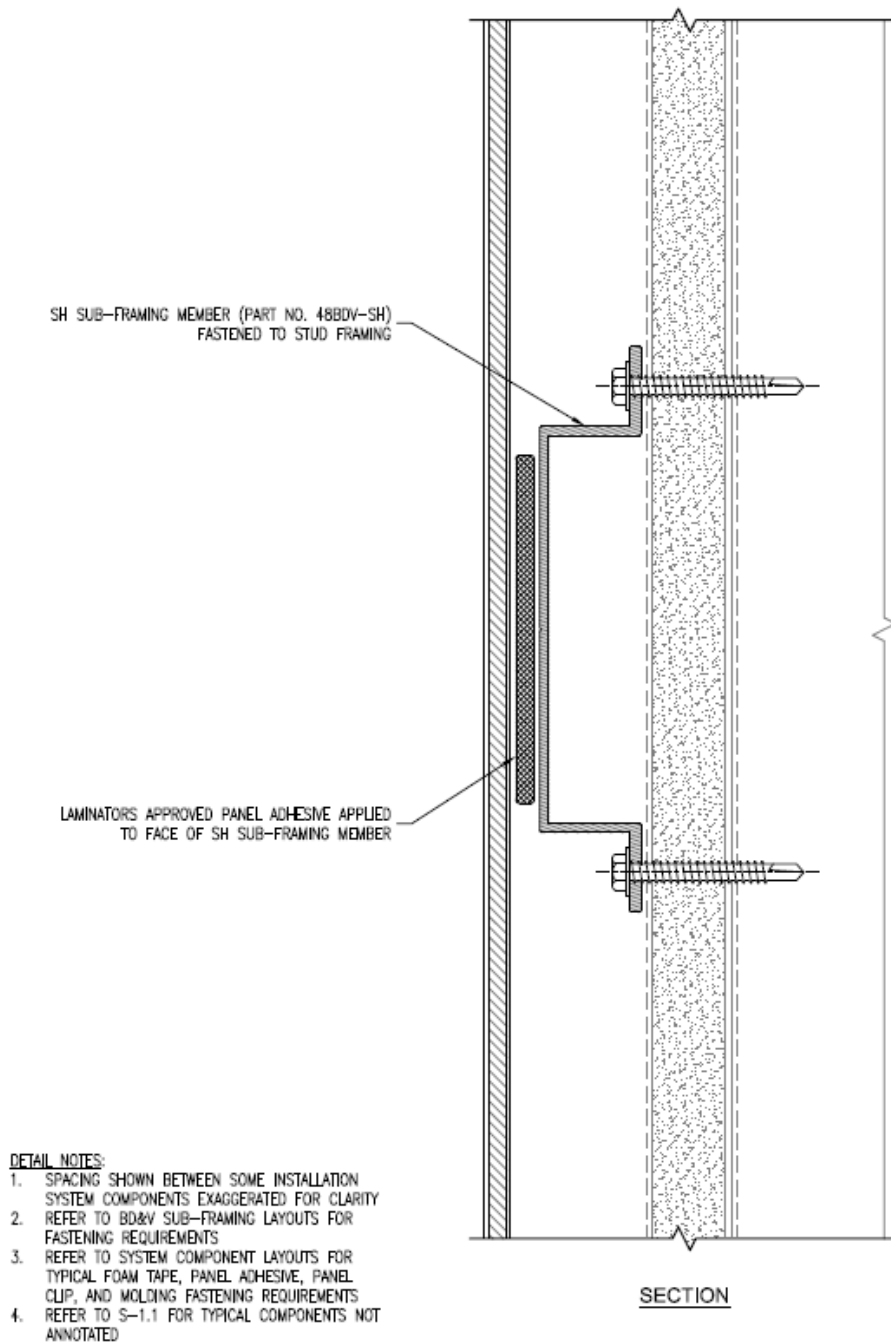
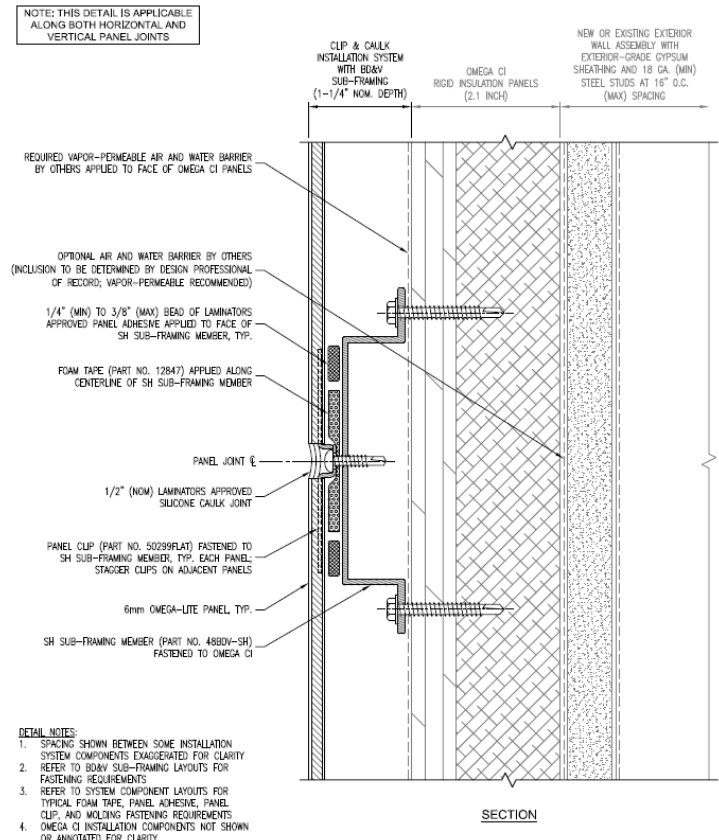
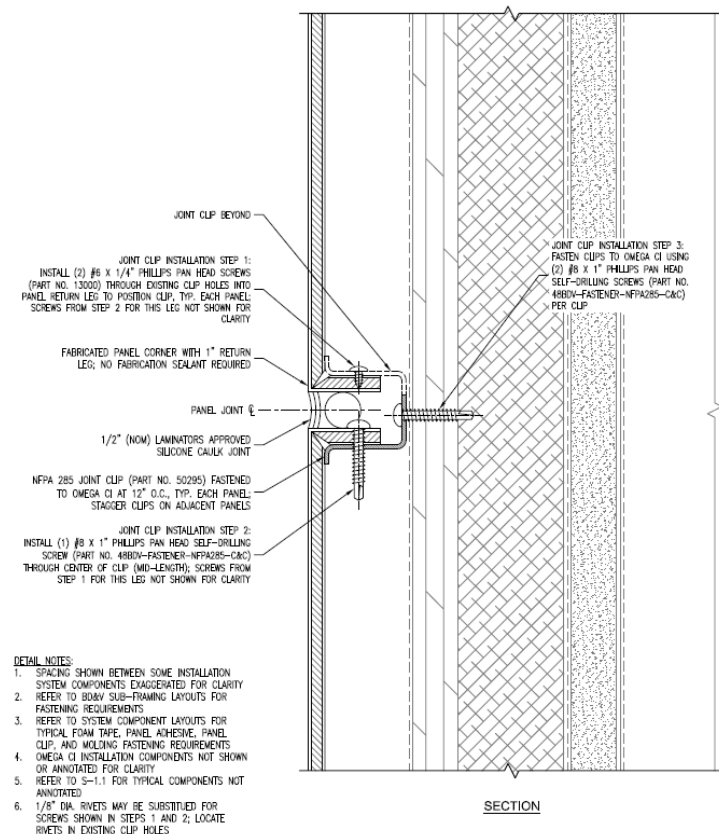

FIGURE 6: CLIP & CAULK INSTALLATION SYSTEM WITH SUB-FRAMING OVER GYPSUM SHEATHING JOINT DETAIL (INTERMEDIATE)



JOINT DETAIL



HORIZONTAL JOINT DETAIL (NFPA 285 ZONE)

FIGURE 7: CLIP & CAULK INSTALLATION SYSTEM WITH SUB-FRAMING OVER OMEGA CI RIGID INSULATION JOINT DETAIL (VERTICAL AND HORIZONTAL)

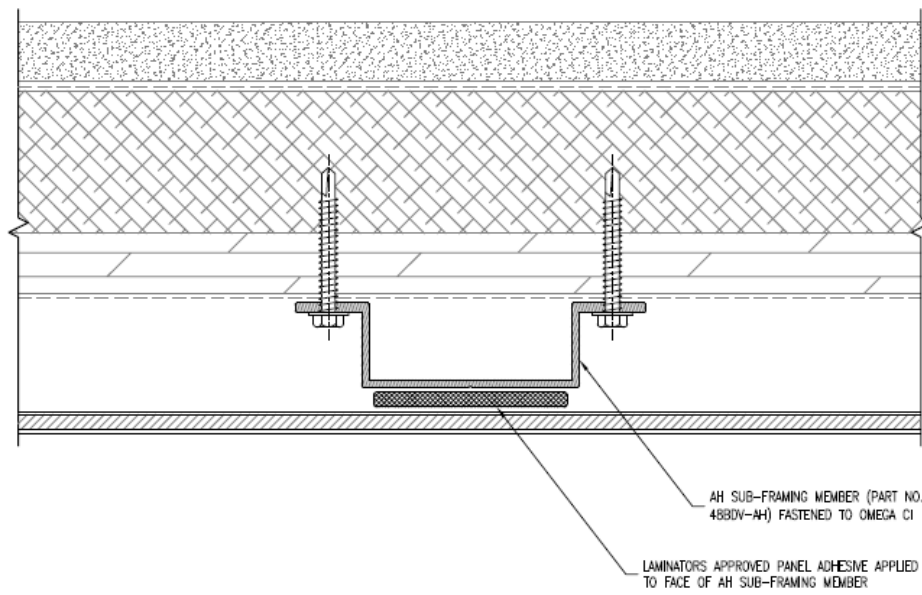

DETAIL NOTES:

1. SPACING SHOWN BETWEEN SOME INSTALLATION SYSTEM COMPONENTS EXAGGERATED FOR CLARITY
2. REFER TO BD&V SUB-FRAMING LAYOUTS FOR FASTENING REQUIREMENTS
3. REFER TO SYSTEM COMPONENT LAYOUTS FOR TYPICAL FOAM TAPE, PANEL ADHESIVE, PANEL CLIP, AND MOLDING FASTENING REQUIREMENTS
4. OMEGA CI INSTALLATION COMPONENTS NOT SHOWN OR ANNOTATED FOR CLARITY
5. REFER TO S-1.1 FOR TYPICAL COMPONENTS NOT ANNOTATED

PLAN SECTION

FIGURE 8: CLIP & CAULK INSTALLATION SYSTEM WITH SUB-FRAMING OVER OMEGA CI RIGID INSULATION JOINT DETAIL (INTERMEDIATE)